

20th EDITION

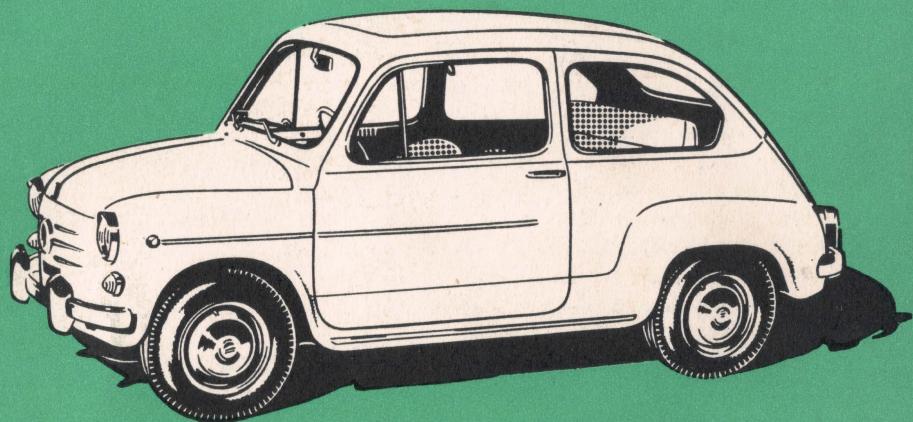

**FIAT**  
**600 D**

**Instruction Book**

# INDEX

	Page		Page
Identification data . . . . .	2	Cooling system . . . . .	26
Keys . . . . .	2	Ignition system . . . . .	27
Service . . . . .	3	Power train . . . . .	29
Run-in period . . . . .	4	Brakes . . . . .	29
<b>Operation</b>		Suspensions . . . . .	32
Doors and seats . . . . .	5	Steering and wheels . . . . .	32
Safety belts . . . . .	6	Car heating . . . . .	34
Luggage accommodation . . . . .	7	Generating and starting equipment	35
Front compartment lid . . . . .	8	Lights . . . . .	36
Engine compartment . . . . .	9	Bodywork . . . . .	39
Gauges and controls on facia . . . . .	10	Accessories . . . . .	39
Starting the engine . . . . .	13	Miscellaneous . . . . .	40
Starting the car . . . . .	14	Tool kit . . . . .	40
On the road . . . . .	14	<b>Specifications</b>	
Winter driving . . . . .	14	Engine . . . . .	41
Parking . . . . .	15	Power train . . . . .	43
Ventilation and heating . . . . .	15	Brakes . . . . .	43
How to change wheels . . . . .	17	Suspension . . . . .	43
Jacking up and towing . . . . .	18	Steering and wheels . . . . .	44
<b>Maintenance</b>		Electric system . . . . .	44
Engine lubrication . . . . .	19	Body . . . . .	45
Valve gear . . . . .	24	Performance . . . . .	46
Fuel system . . . . .	25	Weights . . . . .	46
		<b>Convertible</b> . . . . .	47
		<b>Lubricant characteristics</b> . . . . .	48
		<b>Fill-up data</b> . . . . .	—

## IMPORTANT

The British and American system measures are given merely for Customer's convenience and, though the closest possible approximation is sought, they are sometimes rounded off for practical reasons.

**It is therefore understood that in case of any discrepancy the metric value is the only valid reference.**

## EACH CAR IS SUPPLIED WITH A COPY OF THIS BOOK

where the specific constructional and operation data are described. For the general operation and maintenance instructions common to all cars see the attached booklet

« Safe Motoring Hints ».

# **FIAT** **600D**

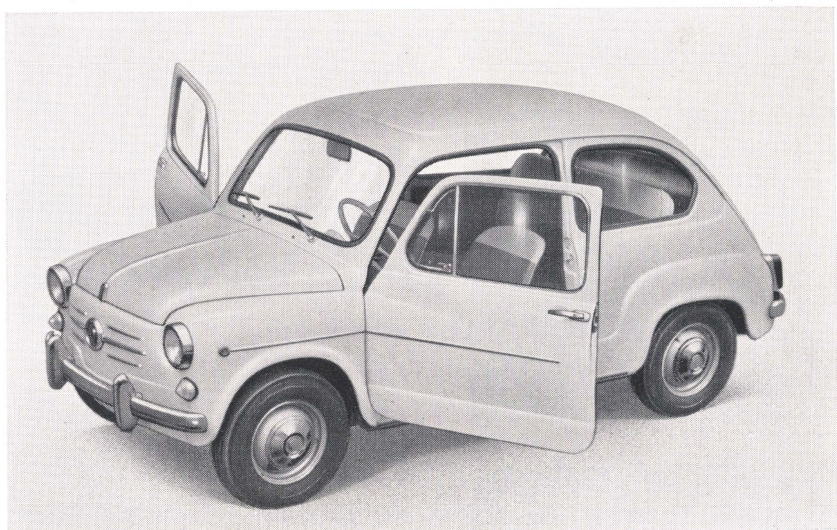

▶ **o p e r a t i o n**

▶ **m a i n t e n a n c e**

▶ **s p e c i f i c a t i o n s**

▶ **appendix: Convertible**

# IDENTIFICATION DATA

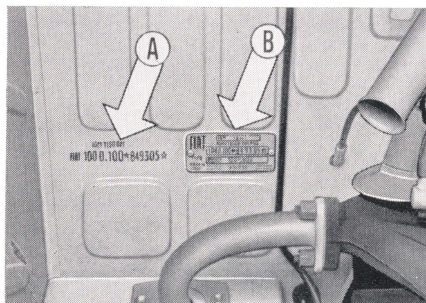

**A - Chassis type (100 D) and number.**

**B - Identification plate.**

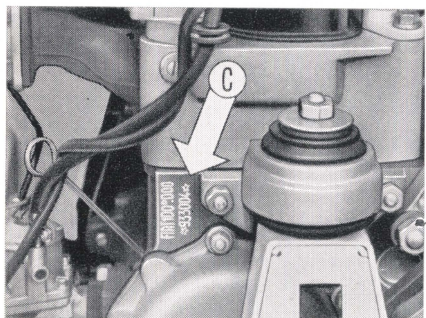

**C - Engine type (100D.000) and number.**

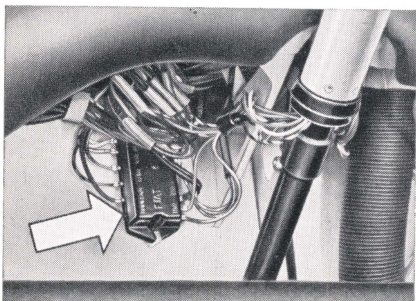

**Fuse box**, arranged under instrument panel, to the left of steering post (see pages 38-39).

## KEYS

Each vehicle is provided with two keys in duplicate: one for ignition lock switch and one for the driver's door. Quoting the code number punched on one key bow face will be sufficient to obtain a spare from FIAT's Sales Organization.

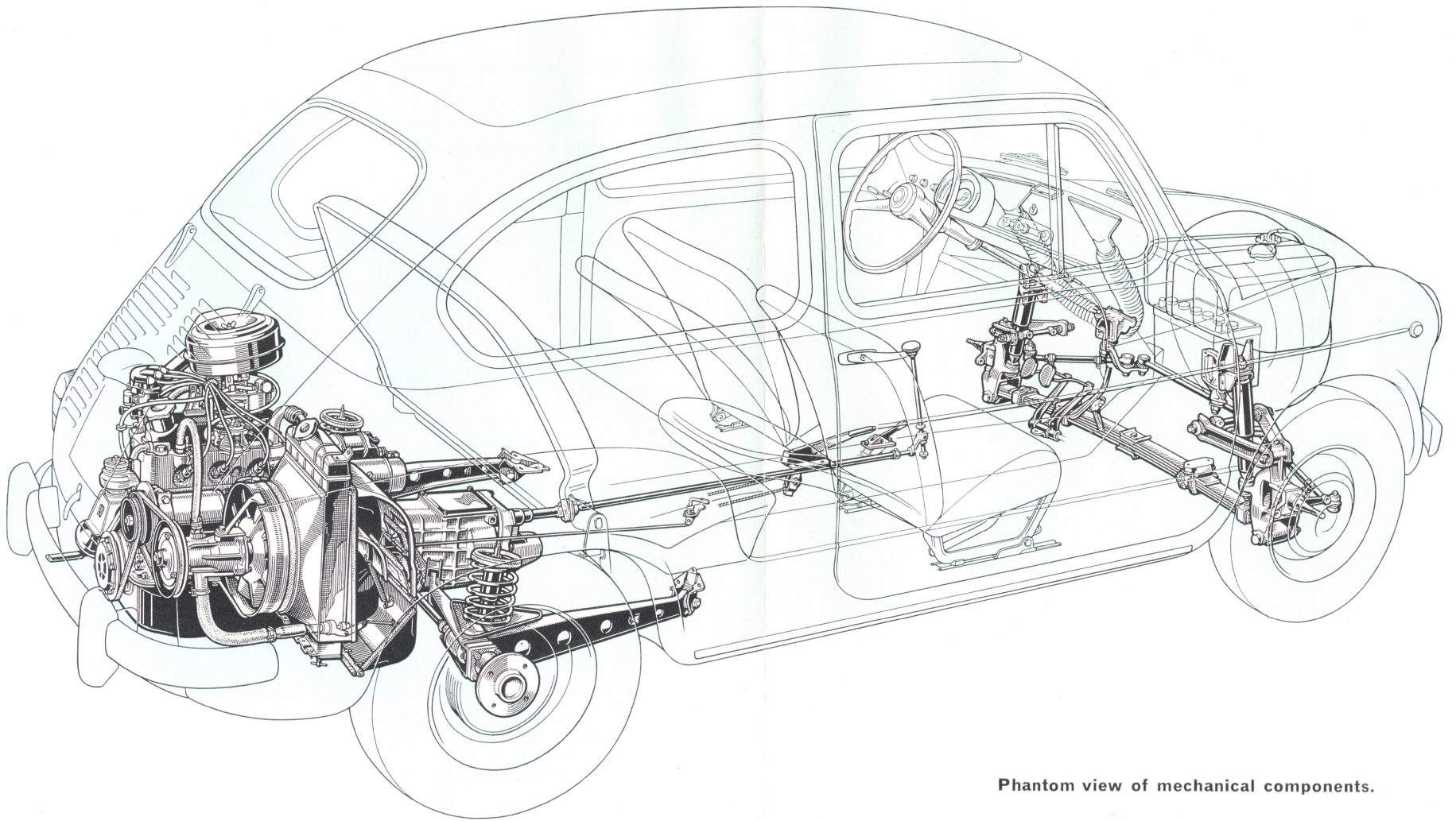

Phantom view of mechanical components.

# SERVICE

---

## OWNER SERVICE CERTIFICATE

All the service operations under warranty are listed in the Owner Service Certificate issued with every new car.

The Certificate includes two Service Coupons covering the free checks, adjustments and lubrication (cost of lubricants excepted) to be performed at the completion of the first 1000-1300 miles and 2500-3500 miles of driving.

It is your own interest to report for Free Service at the specified mileage intervals to obtain best performance and preserve the efficiency of your car.

## SPARE PARTS

Make it a point to use exclusively genuine FIAT parts. It is the best guarantee for top performance and satisfactory operation of all components.

When ordering, quote:

- **Car model.**
- **Engine number** or **Number for Spares**, according to whether engine or chassis-and-body parts are needed.
- **Part number** of spare ordered (see the " Spare Parts Catalog ").

## SERVICE STATIONS

Not all the specified maintenance operations can be carried out easily by the Owner who usually does not have proper equipment at his disposal. Therefore, the car should be taken to one of the many FIAT **Service Stations** established in Italy and abroad for best assistance.

At these authorized FIAT Stations, any overhaul and repair work will be carried out properly thanks to specially designed equipment and experienced personnel.

**FIAT's Organization** is at your disposal. Do not hesitate to write for any explanation or suggestion that will ensure top car performance and best efficiency.

**WHEN YOUR CAR NEEDS SERVICE LOOK FOR THIS SIGN**



## RUN-IN PERIOD

MILEAGE	MAXIMUM PERMISSIBLE SPEEDS							
	1st gear		2nd gear		3rd gear		4th gear	
	km/h	mph	km/h	mph	km/h	mph	km/h	mph
Up to <b>700 km</b> (450 miles) . . .	<b>15</b>	<b>10</b>	<b>25</b>	<b>16</b>	<b>45</b>	<b>28</b>	<b>65</b>	<b>40</b>
From <b>700 to 1500 km</b> (450 to 900 miles) . . . . .	<b>20</b>	<b>13</b>	<b>30</b>	<b>19</b>	<b>55</b>	<b>34</b>	<b>80</b>	<b>50</b>
From <b>1500 to 3000 km</b> (900 to 1800 miles)	Speed limits may be gradually increased up to max. rated speeds.							

- ▶ When car is new, **a running-in of at least 3000 km (1800 miles) is required**; therefore, **never** exceed the running-in speeds indicated above and on the windshield decal.
- ▶ After starting, **do not race the engine**; warm up gradually.
- ▶ **Never drive at the maximum permissible speeds** for long stretches, and do not lug the engine, **especially when climbing**.
- ▶ The crankcase running-in oil **must be replaced by the recommended oil only after the first 1000-1300 miles**. Coupon **A** of the **Service Certificate**.

# OPERATION

## DOORS AND SEATS

The driver's side door handle is provided with a key-controlled lock.

Courtesy light in rear view mirror turns on when door is opened.

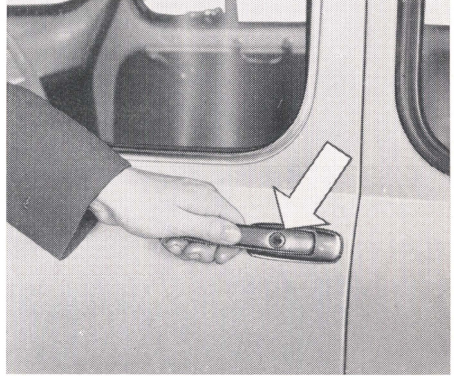

The door on opposite side may be unlocked only from inside by a lever that may assume the following three positions:

- 1 = Open.
- 2 = Closed.
- 3 = Locked (cannot be opened from outside).

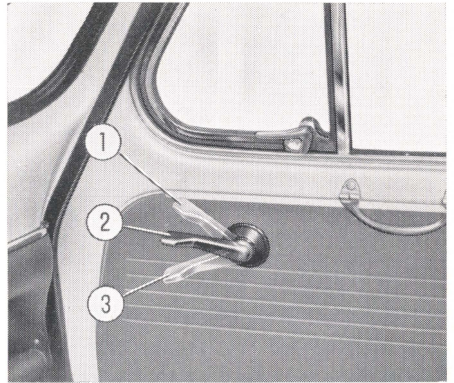

*Lubrication of lock cylinders is not recommended; at the most, blow some graphite powder into the cylinder slot.*

Front seats position on floor is adjusted by moving the control lever rightwards.

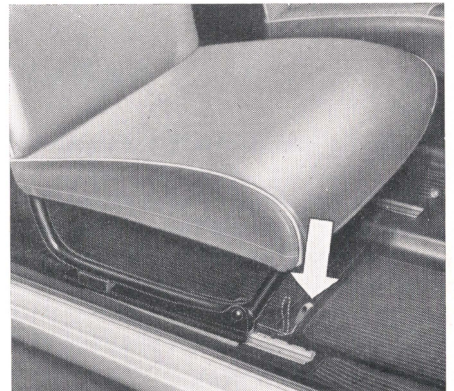

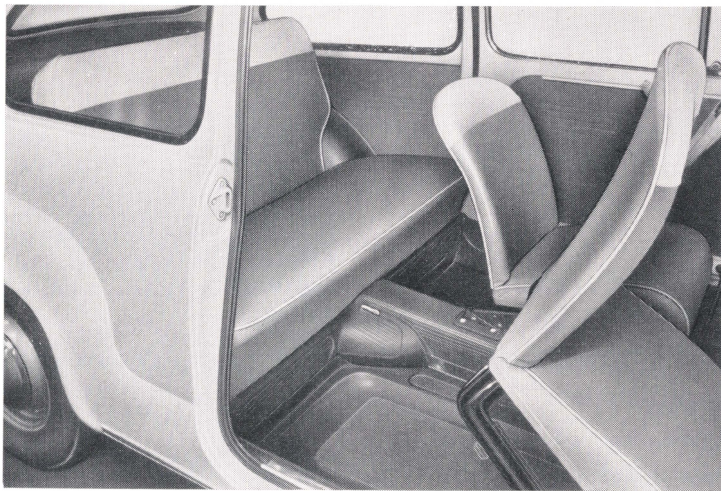

To facilitate access to rear compartment tilt front seats forward.

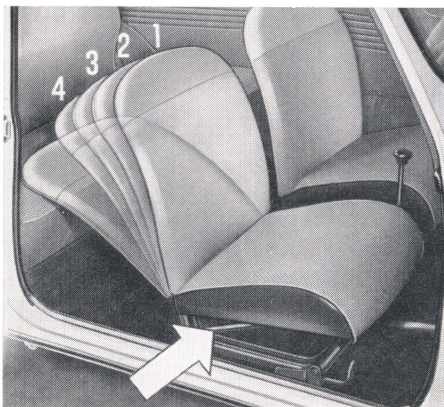

**Optional extra front seats:** with squabs reclinable and adjustable by lifting up a bar lever under the seat. When lever is released the squab locks in one of the 4 positions shown. Beyond the 4th position the squab drops freely and may be rested on rear seat cushion.

## SAFETY BELTS

This car is provided with the necessary arrangements for the application of safety belts for the front seat occupants.

For the anchoring of diagonal type belts use the holes drilled in floor at both sides of tunnel while below rear quarter windows — in right and left side panels — drill four 9 mm (.35") holes in reference dimples (be careful to clear the threads of the underlying welded blocks).

For the anchoring of lap type belts use said holes at tunnel sides and the holes already drilled in floor near doors, behind front seats. Floor holes are blanked by rubber plugs and covered by rubber matting.

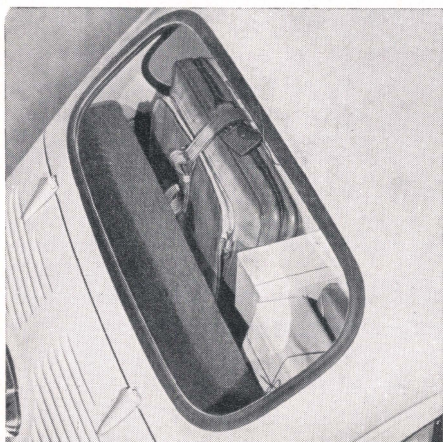

## LUGGAGE ACCOMMODATION

Luggage space behind rear seat that may be increased by tilting the back down over cushion.

Additional luggage space in front compartment.



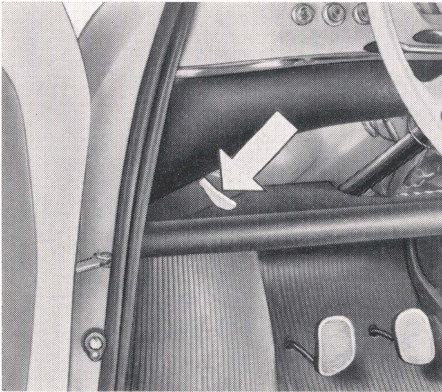

## FRONT COMPARTMENT LID

To release front lid, pull the control.

To lift the lid, insert fingers and push in the safety catch **A**.

Lid is kept raised by prop **B**.



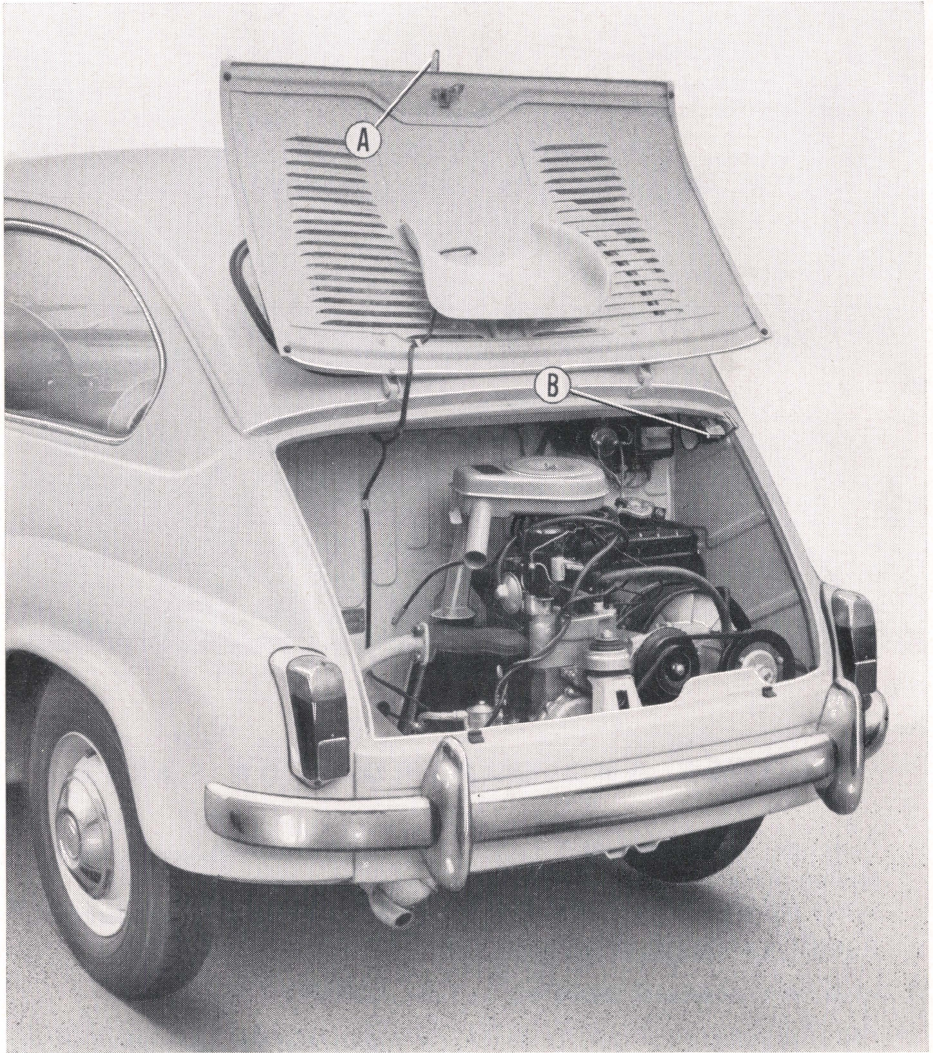

## ENGINE COMPARTMENT

To open the lid pull handle **A** and lift. Bulb **B** will light up automatically if outer lighting switch is ON.

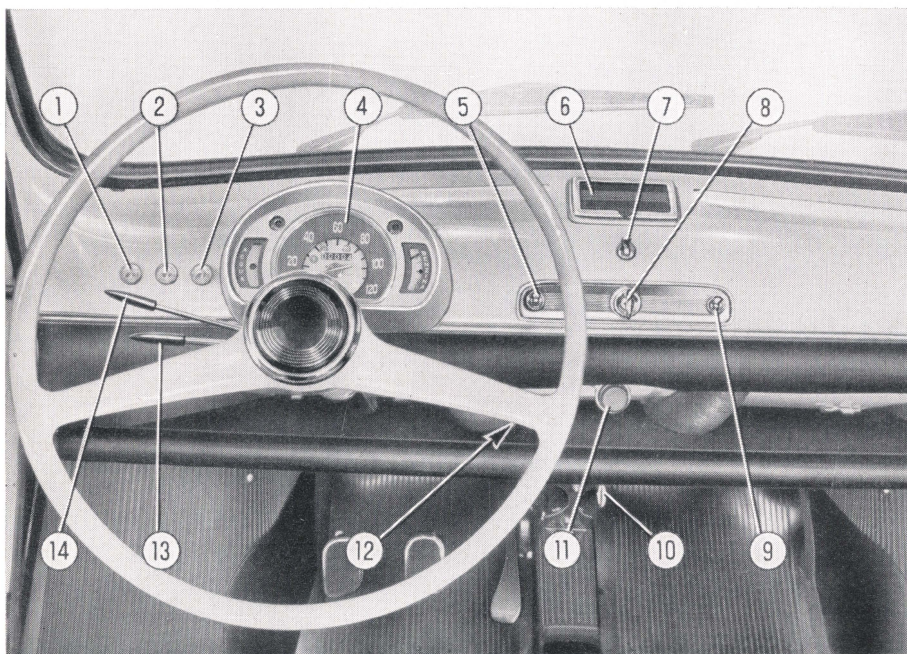

LHD cars.

## GAUGES AND CONTROLS ON FACIA

- 1) **Direction indicators pilot light (green)** flashes when lever 13 is moved up or down.
- 2) **Parking lights indicator (green) (\*)**.
- 3) **High beam indicator (blue) (\*)**.
- 4) **Instrument cluster, incorporating:**
  - a) **Excessive water temperature indicator (red):** lights up when engine overheats.
  - b) **Generator charge indicator (red):** lights up when ignition is turned on and goes out when generator reaches cutting-in speed [engine speed over 920 rpm; car at 20,5 km/h (12,7 miles) in 4th gear].

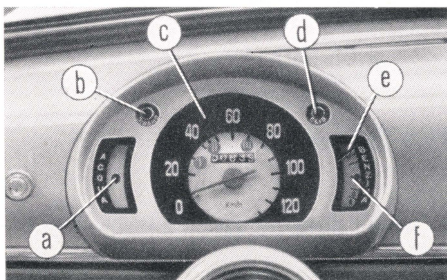

(\*) Light intensity is adjustable by turning the lens.

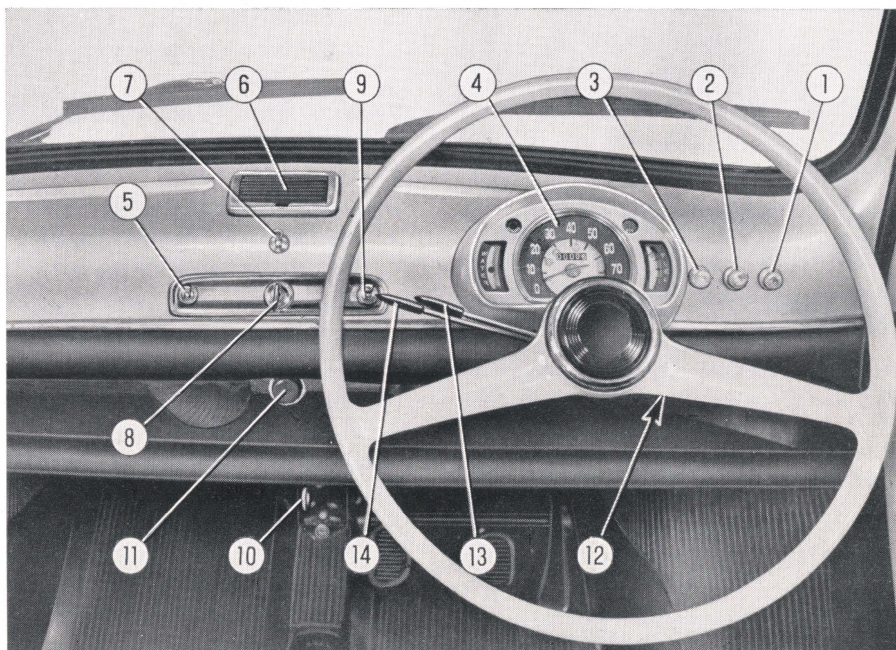

*RHD cars.*

**c) Speedometer-mileage recorder:**

Red spots on dial indicate maximum speed limits (after running-in).

**d) Insufficient oil pressure indicator (red):**

is out when oil pressure is sufficient to ensure proper engine lubrication. When engine is hot and rpm low, the indicator may turn ON even if everything is normal.

**e) Fuel level gauge.**

**f) Fuel reserve indicator (red):** lights up when only 3,5 to 5 liters (.9-1.3

U.S. or .8-1.1 G.B. Gals) of fuel remain in tank.

**5) Instruments cluster light switch.**

**6) Ash tray:** remove it from facia for emptying and cleaning by pushing it up from below.

**7) Outer lighting switch:** turns ON the parking lights, the number plate lamp and energizes the switch controlled by lever (14).

**8) Lock switch.** (see figure on page 12).

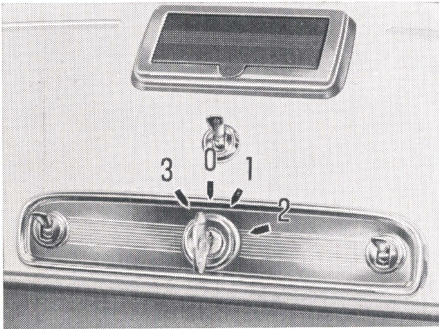

**Position 0:** all OUT (key can be pulled out).

**Position 1:** ignition ON and services energized.

**Position 2:** starter ON.

**Position 3:** parking and number plate lights ON, with switch 7, page 10, ON and outer lighting change-over switch lever 14 in position I (key can be pulled out).

**Note - With engine inoperative** never leave key in position 1. In this position, the switch controls ignition and starting, and energizes the following circuits:

fuel level gauge and reserve indicator; generator charge indicator; insufficient oil pressure indicator; excessive water temperature indicator; direction indicators and pilot light; rear stop lamps; head-lamps (high beams, low beams and flashes) high beam indicator; parking lamps and relevant indicator; number plate lamp; engine compartment light; instrument cluster light; windshield wiper.

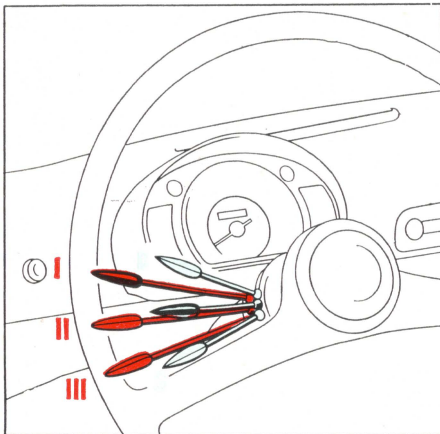

**9) Windshield wiper switch with automatic blade parking.**

**10) Ring grab control:** pull to admit warm air into car.

**11) Windshield washer pump:** to wash the windshield depress several times the rubber bulb, at the same time turning on the windshield wiper switch (9).

**12) Hand accelerator (throttle).**

**13) Direction indicators control lever:**

**D** = right turn.

**S** = left turn.

The lever returns automatically to OFF position when steering wheel is back to straightahead drive position.

**14) Outer lighting change-over switch lever** (operative with switch 7, page 10, turned on):

**I:** number plate lamp, front and rear parking lamps;

**II:** number plate lamp, front and rear parking lamps and head-lamp low beams;

**III:** number plate lamp, front and rear parking lamps and head-lamp high beams.

In position I and III, by tripping the lever toward the steering wheel flashing of headlamp low beams is obtained. With switch 7 OFF the low beam flashes can be obtained with lever in any of the three positions.

# STARTING THE ENGINE

## Cold starts

Set the controls as follows:

- a) Gearshift lever in neutral.
- b) Choke lever **A** pulled fully up.
- c) Clutch pedal: fully depressed (this is recommended, especially when engine is cold).

With controls set as described:

- Insert and turn lock switch key clockwise to the stop, i.e., position **2** (page 12) and keep it there until engine is started up. Then, release hold and key will snap back to position **1**.
- Once engine has started, push knob home **gradually** to ensure a smooth running of engine during warm up.
- **Do not step on accelerator pedal** until engine has started.

**Avoid sudden accelerations when engine is cold.**

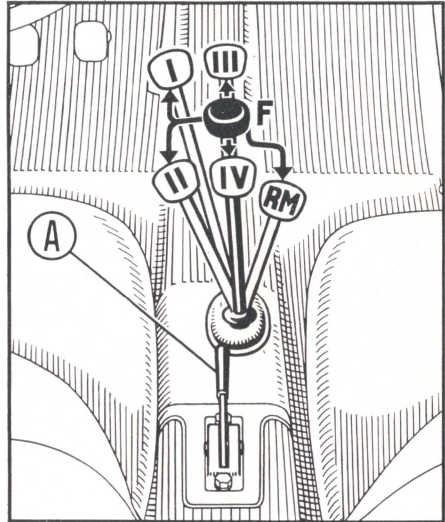

**F** = Neutral      **RM** = Reverse

**Press in lever to engage reverse.**

## Hot starts

When engine is warm leave choke lever **A** down.

When engine is hot it might be necessary to **depress** accelerator pedal **fully**; then, release pedal as soon as engine fires.

**Do not pump the accelerator**, as each pedal stroke actuates the accelerating pump which, by providing an excessively rich mixture, would render engine starting difficult.

## STARTING THE CAR

- a) Declutch.
- b) Engage 1st gear.
- c) **Release** hand (auxiliary) brake (press button on grip top and push down).
- d) Release clutch pedal gradually and at the same time accelerate slowly.
- e) Next, shift up to the higher gears as required.

## ON THE ROAD

- **Never exceed** (even on down-grades) the speed limits indicated by red spots on speedometer dial, and the recommended top speed.
- During regular engine operation, all **warning indicators (red)** on panel **must be OFF**. If any one lights up, investigate and remedy accordingly.

## WINTER DRIVING

Besides using antifreeze mixtures to ensure adequate engine protection (see *Safe Motoring Hints*) **rotate** 120° the butterfly valve lever on cleaner intake duct to exclude the admission of cold air.

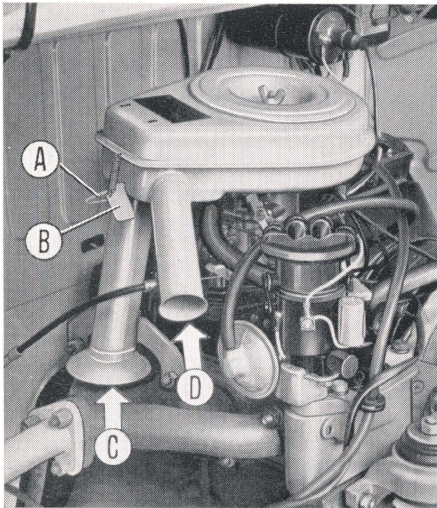

- A.** Lever positioned for admission of air warmed up by exhaust manifold.
- B.** Lever positioned for normal air admission.
- C.** Warm air intake (winter: lever set with wing under reference **I**).
- D.** Normal air intake (summer: lever set with wing under reference **E**).

## PARKING

When the car must be left unattended on a slope, apply the auxiliary brake and **engage either the 1st gear or reverse** depending on whether the car is headed uphill or downhill.

At night, and in dark areas, set lock switch key in position **3**, page 12, - i.e., parking and number plate lights ON.

## VENTILATION AND HEATING

**Summer ventilation.** Swivelling ventipanes and regulator-controlled drop window on doors.

**Winter heating.** To demist and defrost the windshield turn the lever **A** rightwards (first stop). To heat car interior, open outlets **C** by pulling ring grab **B**. By moving the lever **A** to stroke end, warm air is admitted also through luggage space behind rear seat.

To promote air circulation inside car open slightly one of the ventipanes.

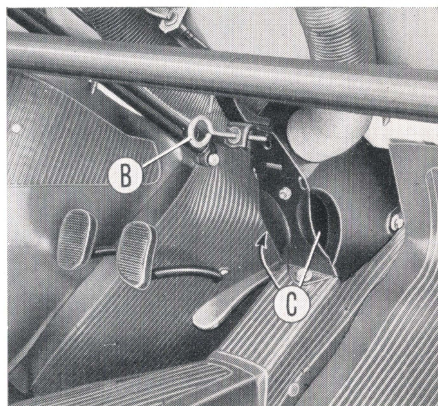
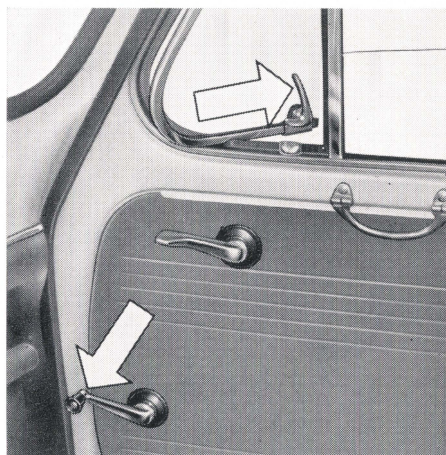

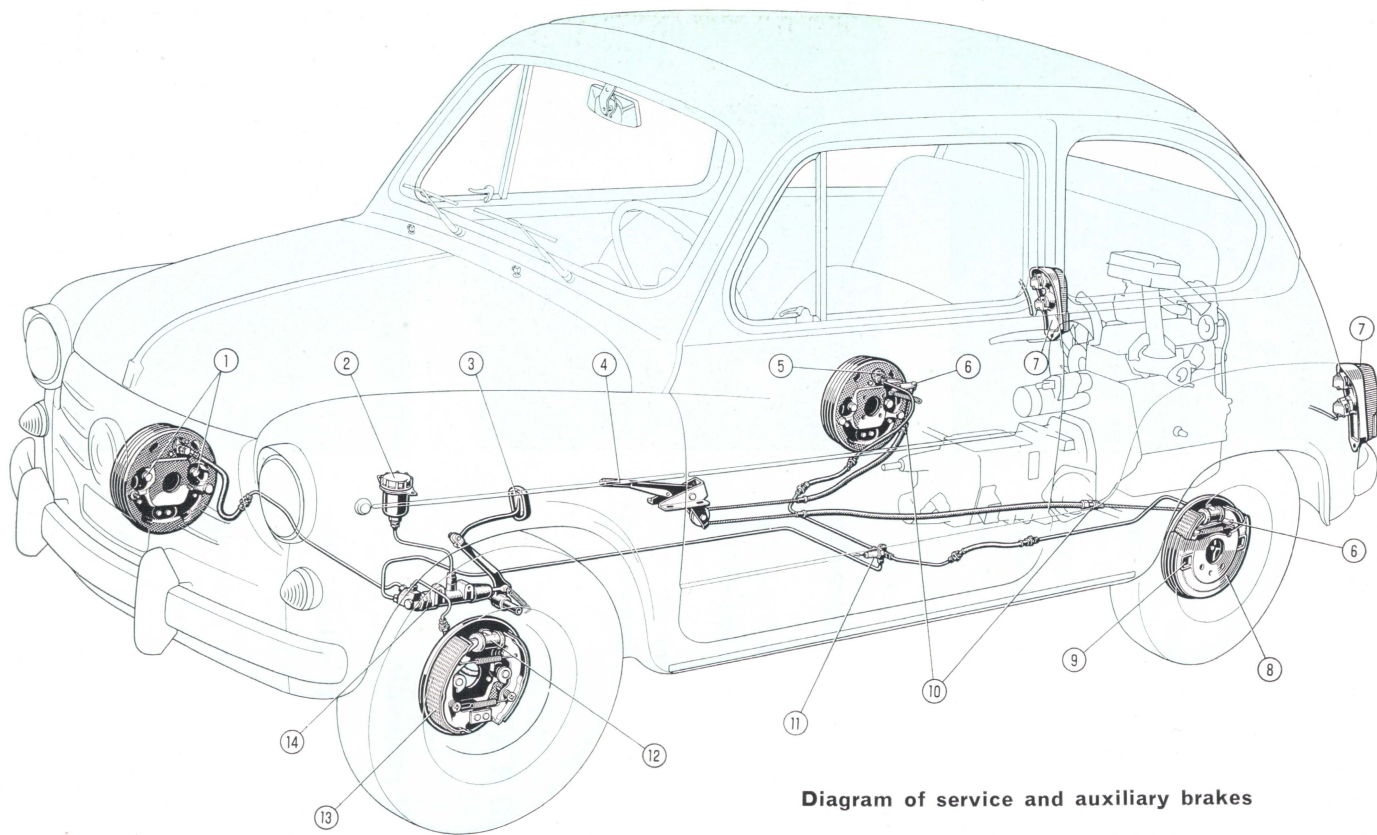

**Diagram of service and auxiliary brakes**

- 1.** Shoe-to-drum clearance adjustment cam pins - **2.** Brake fluid reservoir -  
**3.** Service brake pedal - **4.** Auxiliary brake hand lever - **5.** Brake system  
bleeding connection - **6.** Brake operating lever, mechanically controlled by  
lever (4) - **7.** Stop lights - **8.** Brake drum - **9.** Slot for shoe-to-drum clearance adjustment - **10.** Brake mechanical control  
adjustment stretchers - **11.** Stop lights pressure-operated switch - **12.** Wheel cylinder - **13.** Brake shoes - **14.** Master cylinder.

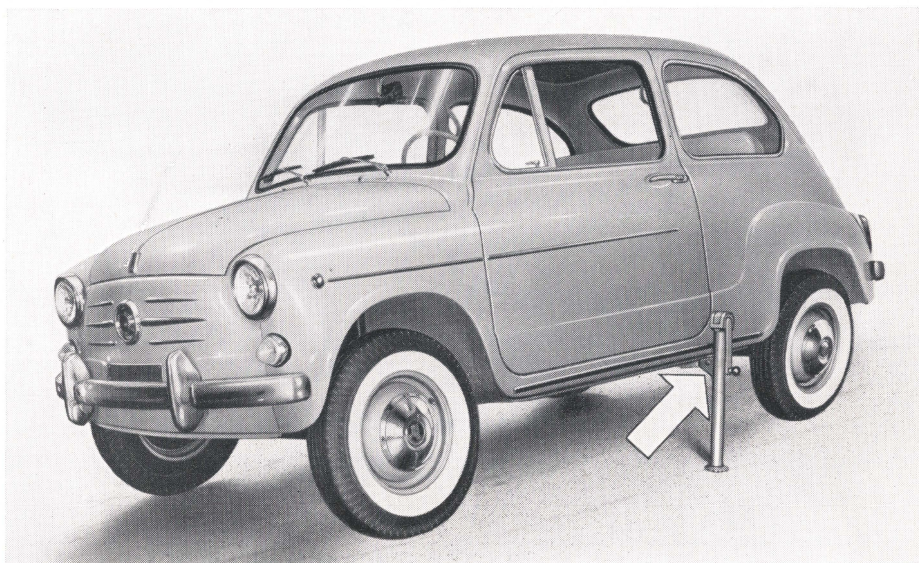

## HOW TO CHANGE WHEELS

To do this job properly, proceed as follows:

- a) Place car possibly on level ground and lock rear wheels by the hand brake.
- b) Pry wheel cap off. Using the speed handle slacken about one turn the four wheel fixing screws.
- c) Place jack nub in bracket under body floor, then jack up until the wheel to be removed clears the ground.
- d) Undo and remove the four fixing screws. Pull off wheel.
- e) Fit spare wheel. The wheel location dowel on brake drum must fit into the hole provided in wheel disc.
- f) Insert wheel fixing screws and tighten uniformly in criss-cross sequence.
- g) Lower car and disinsert jack nub from bracket under floor.
- h) Tighten wheel fixing screws fully and snap on wheel cap firmly.

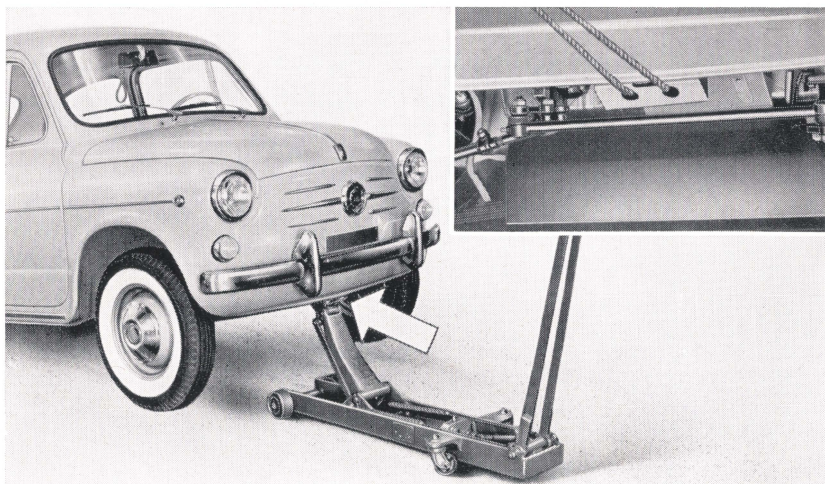

## JACKING UP AND TOWING

When either the front or rear end of car must be raised with a garage jack, it is indispensable to fit jack head under the special brackets, as shown.

At rear, a wooden block at least 3 cm

thick must **always** be interposed between jack head and bracket.

If car needs towing, the rope must be attached exclusively on the front central jack bracket (see inset).



# M A I N T E N A N C E

## CONSULTING THE CHARTS

The periodical maintenance operations recommended in relation to given mileages, are listed in two charts covering respectively the lubrication points and the cleaning, inspection and adjustment operations.

Each operation is identified by a number and, in the corresponding note, reference is made to the page where the operation is described. In the lubrication chart a set of symbols indicates the grade of lubricant to be used. For oils not mentioned here, see « Fill-up Data ».

Particular stress is laid on the importance of reporting to a FIAT Service Station for all the maintenance operations marked



**NOTICE** - Besides the routine maintenance operations listed in the charts this chapter describes other operations that must be performed only in exceptional cases of defective operation of mechanical units and with which the car Owner should become familiar.

## ENGINE LUBRICATION

### *Sump*

**Every 500 km (300 miles):** check oil level which must always result between **Min** and **Max** marks on indicator rod and top up if required.

**Every 10.000 km (6,000 miles)** or 6 months, whichever occurs first: replace oil with **warm** engine.

When engine is new replace oil after the first 1000-1300 miles and 2500-3500 miles - operation covered by Coupons **A** and **B** of the **Service Certificate**.

### *By-pass oil filter*

**Every 10.000 km (6,000 miles):** replace cartridge i.e. at every oil change.

**Never run engine when cartridge is not in filter.**

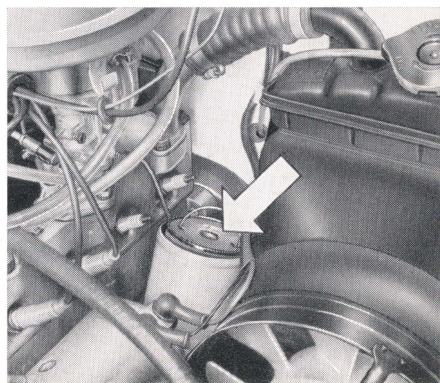
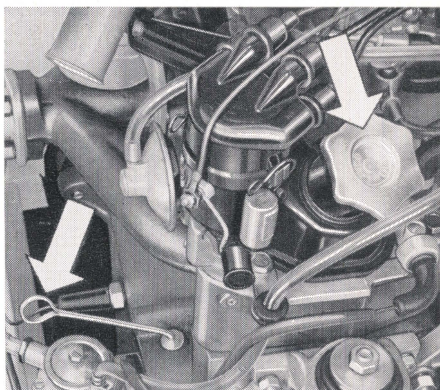

**20.000 km**  
(12,000 miles)

**10.000 km**  
(6,000 miles)

**500 km**  
(300 miles)

**20.000 km**  
(12,000 miles)

**10.000 km**  
(6,000 miles)

**500 km**  
(300 miles)

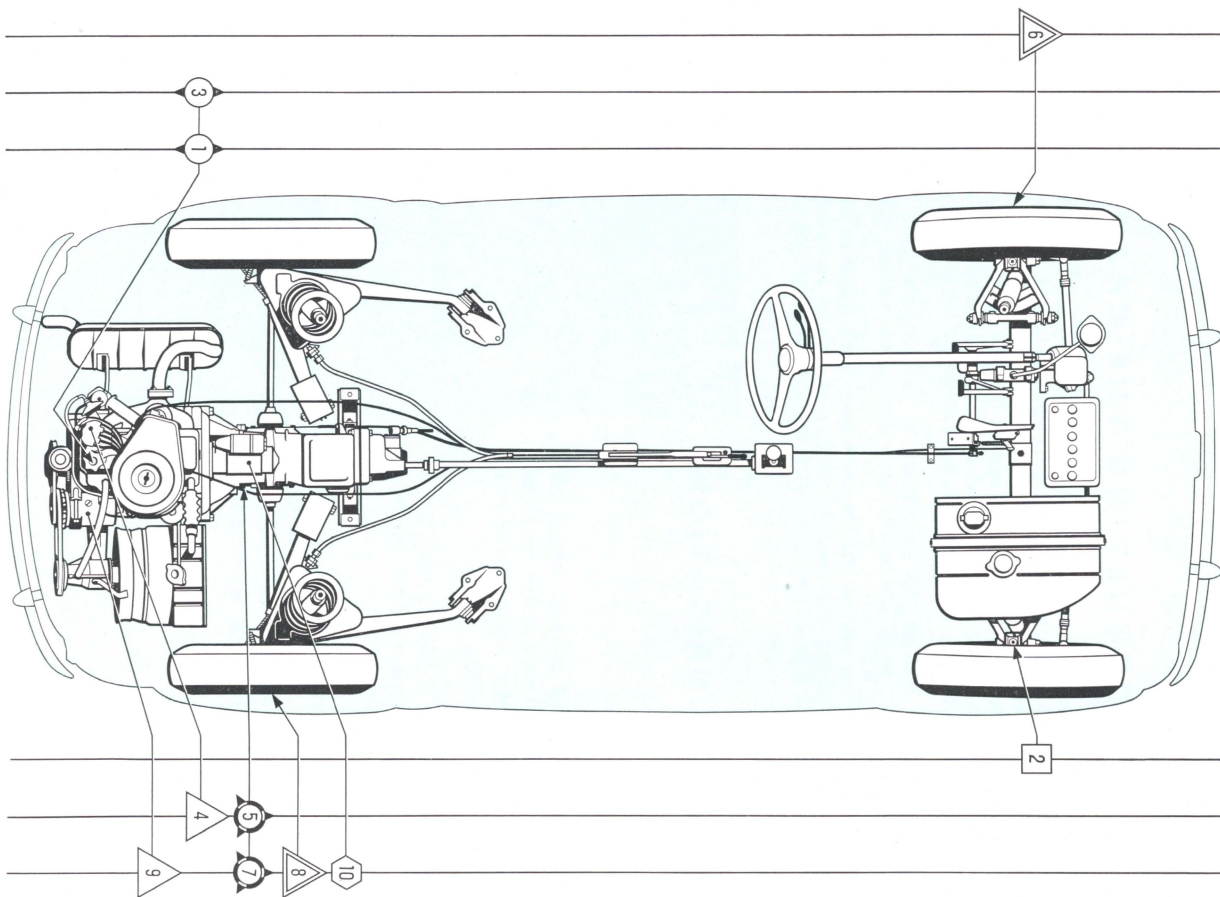

**2.500 km**  
(1,500 miles)

**10.000 km**  
(6,000 miles)

**30.000 km**  
(18,000 miles)

**2.500 km**  
(1,500 miles)

**10.000 km**  
(6,000 miles)

**30.000 km**  
(18,000 miles)

## LUBRICATION CHART

### Every 500 km (300 miles)

1. Sump . . . . . see page 19

### Every 2.500 km (1,500 miles)

2. Kingpins . . . . . » 32

### Every 10.000 km (6,000 miles)

3. Sump . . . . . » 19  
 4. Ignition distributor . . . . . » 27  
 5. Transmission and differential . . . . . » 29

### Every 20.000 km (12,000 miles)

6. Front wheel bearings . . . . . » 34  
 — Door hinges . . . . . » 39

### Every 30.000 km (18,000 miles)

7. Transmission and differential . . . . . » 29  
 8. Rear wheel bearings . . . . . » 34  
 9. Generator . . . . . » 35  
 10. Starter . . . . . » 35

## LUBRICANTS



FIAT engine oil  
(See "Fill-up Data")



FIAT W 90/M oil



FIAT Jota 1  
grease



FIAT Jota 2/M  
grease



FIAT MR 3 grease

**30.000 km**  
(18,000 miles)

**20.000 km**  
(12,000 miles)

**10.000 km**  
(6,000 miles)

**500 km**  
(300 miles)

**2.500 km**  
(1,500 miles)

**10.000 km**  
(6,000 miles)

**30.000 km**  
(18,000 miles)

**20.000 km**  
(12,000 miles)

**10.000 km**  
(6,000 miles)

**500 km**  
(300 miles)

**2.500 km**  
(1,500 miles)

**10.000 km**  
(6,000 miles)

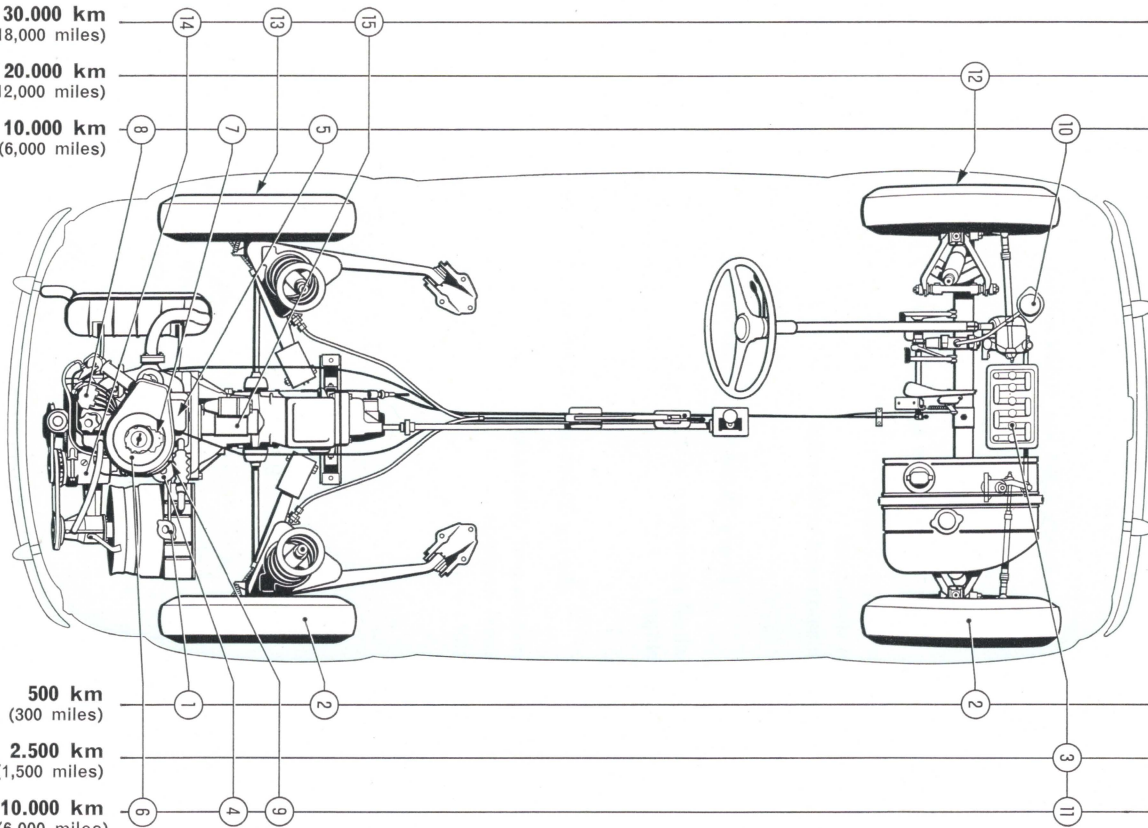

## CLEANING, INSPECTION AND ADJUSTMENT CHART

### Every 500 km (300 miles)

- |                             |          |    |
|-----------------------------|----------|----|
| 1. Water radiator . . . . . | see page | 26 |
| 2. Tires . . . . .          | »        | 34 |

### Every 2.500 km (1,500 miles)

- |                      |   |    |
|----------------------|---|----|
| 3. Battery . . . . . | » | 35 |
|----------------------|---|----|

### Every 10.000 km (6,000 miles)

- |                                     |   |    |
|-------------------------------------|---|----|
| 4. By-pass oil filter . . . . .     | » | 19 |
| 5. Valve tappet clearance . . . . . | » | 24 |
| 6. Air cleaner . . . . .            | » | 25 |
| 7. Carburetor . . . . .             | » | 25 |
| 8. Ignition distributor . . . . .   | » | 27 |
| 9. Spark plugs . . . . .            | » | 28 |
| 10. Brake fluid reservoir . . . . . | » | 29 |
| 11. Battery . . . . .               | » | 35 |
| — Road test . . . . .               | » | 40 |

### Every 20.000 km (12,000 miles)

- |  |   |    |
|--|---|----|
| 12. Front wheel bearings . . . . .             | » | 34 |
| — Mechanical units anchoring to body . . . . . | » | 39 |

### Every 30.000 km (18,000 miles)

- |                                   |   |    |
|-----------------------------------|---|----|
| 13. Rear wheel bearings . . . . . | » | 34 |
| 14. Generator . . . . .           | » | 35 |
| 15. Starter . . . . .             | » | 35 |

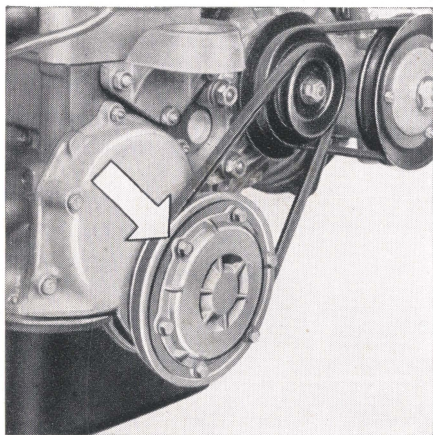

### ***Centrifugal oil filter***

Disassemble and clean the filter accurately only when proceeding with a general overhaul of engine.

## **VALVE GEAR**

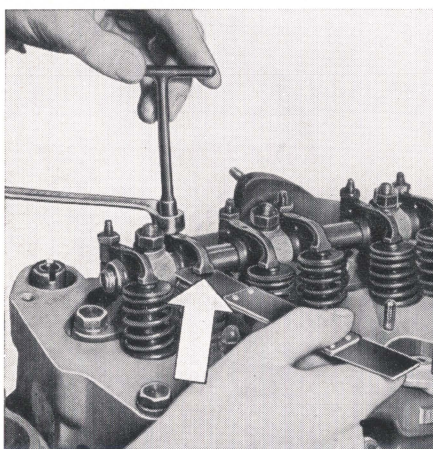

### ***Valve tappet clearance***

**Every 10.000 km (6,000 miles):** or whenever tappet operation becomes noisy, check valve tappet clearance; specified clearance, **with cold engine**, is 0,15 mm (.006") both for intake and exhaust valves. **When engine is new**, check valve tappet clearance after the first 1000-1300 and 2500-3500 miles - operation covered by Coupons **A** and **B** of the **Service Certificate**.

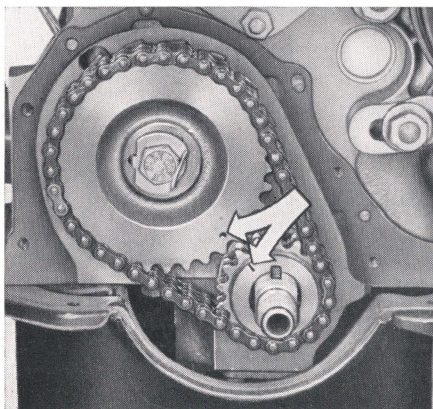

### ***Valve timing***

With reference marks lined up as shown timing is correct.



Timing checks, if necessary, should be performed by a Service Station.

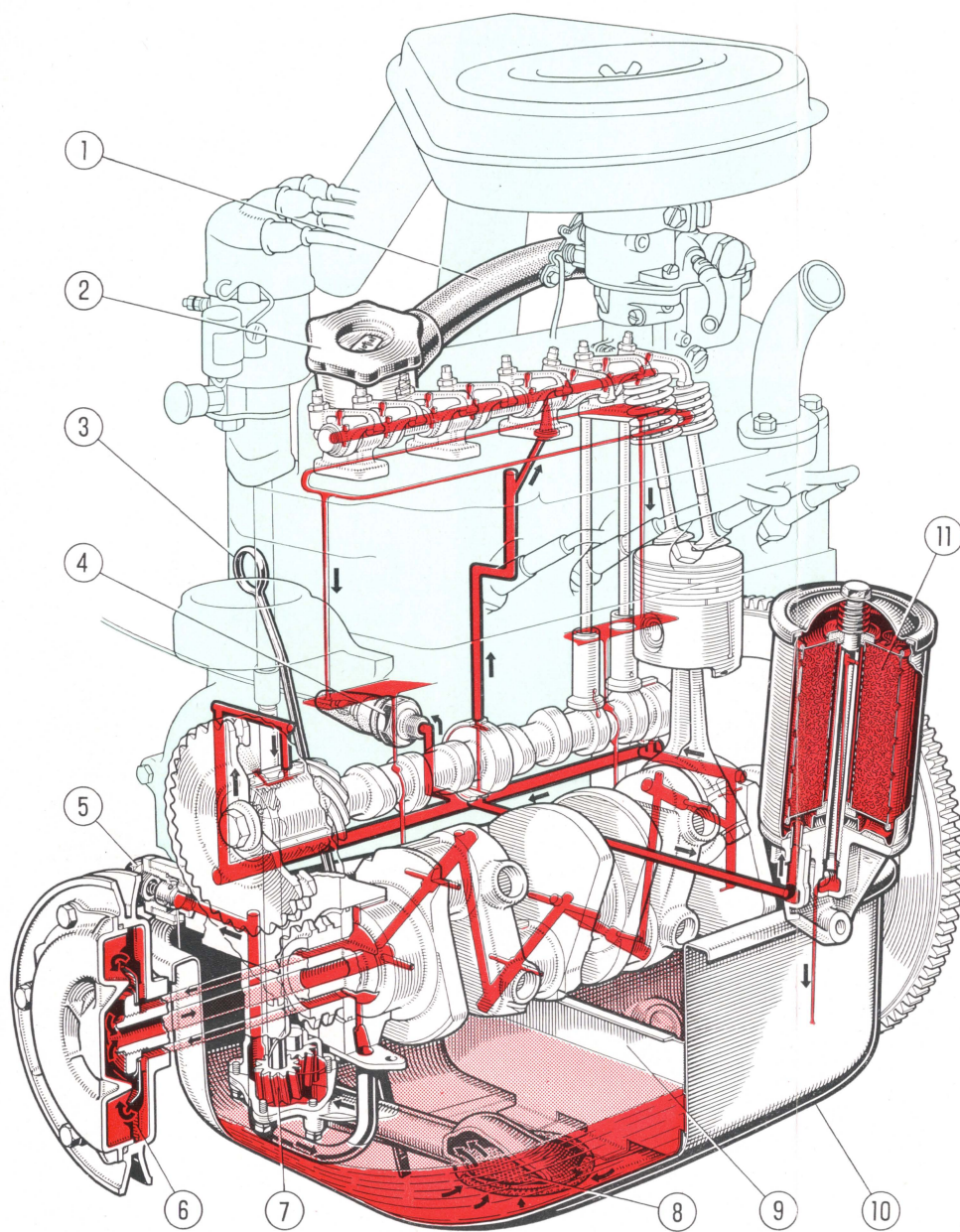

**Engine lubrication diagram**

1. Crankcase vapors recirculation line to air cleaner.
2. Oil filler cap.
3. Oil level indicator rod.
4. Insufficient oil pressure indicator sending unit.
5. Oil pressure relief valve.
6. Centrifugal oil filter.
7. Oil gear pump.
8. Oil pump suction filter.
9. Antislosh baffle.
10. Oil sump.
11. By-pass filter replaceable cartridge.

## FUEL SYSTEM (\*)

### Air cleaner

Every 10.000 km (6,000 miles): undo wingnut **A**, remove and replace element **B**.

Replace filtering element at shorter intervals if car is operated under extreme dust conditions.

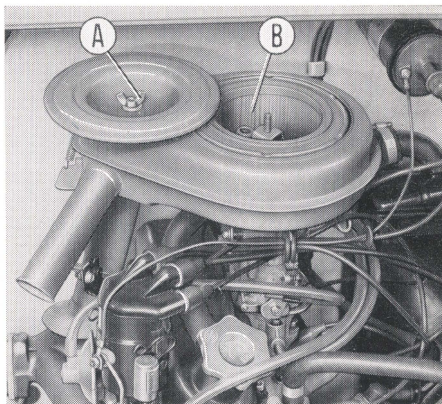

### Carburetor

If engine, though warm, tends to stop at idle speed, correct throttle opening slightly by setscrew **A**. Screw **B** varies idle mixture richness.

Every 10.000 km (6,000 miles): clean carburetor jets **C** and **D** and inner strainer **E**.

This cleaning should be performed exclusively by using an air blast.

Performance of the above operations requires the necessary know-how.



Always consult a FIAT Service Station when carburetor develops major troubles.

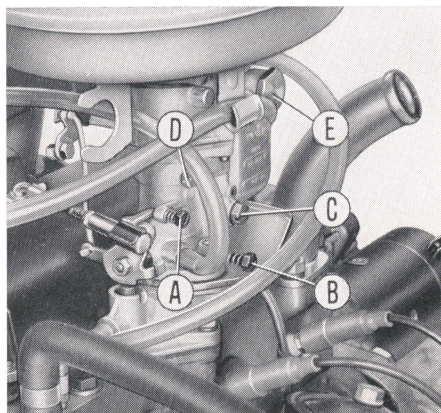

Weber carburetor.

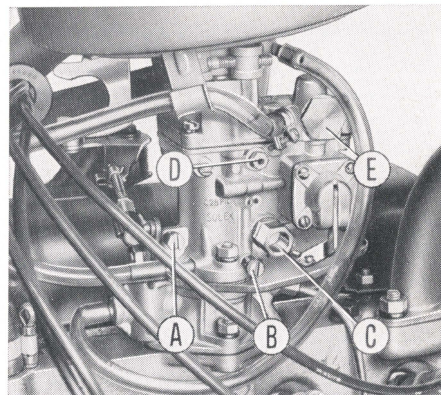

Solex carburetor.

(\*) Before disassembling fuel pump and relevant lines for cleaning and inspection, disconnect the hose from connection on fuel tank to prevent syphoning of fuel through the suction pipe.

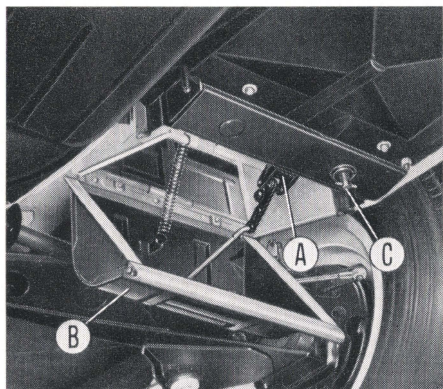

## COOLING SYSTEM

### *Water radiator*

**Every 500 km (300 miles):** check water level, and if necessary, top up.

When ambient temperature is close to 0° C replace the water with an antifreeze mixture (See « *Safe Motoring Hints* »).

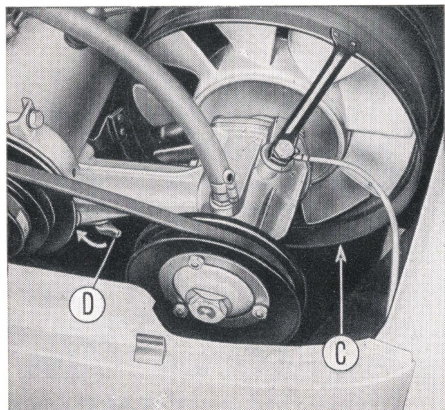

Should topping up be required more frequently than recommended, causes generally are:

- Faulty radiator steam vent valve.
- Leaky hoses.
- Inadequate tightness of water pump inner seals, causing leakages through drain holes in pump body and cover.
- Slack generator, water pump and fan drive belts.
- Operation of thermostat **A** installed in radiator lower tank, which is adjusted to open gradually shutter **B**.

**Caution** - In case of faulty operation of thermostat **A** or its linkage whereby shutter **B** does not open at the specified temperature or remains stuck, resulting in cooling water overheating (signalled by indicator **a**, page 10) air circulation within engine compartment can be obtained just the same by pulling the shutter wide open manually.



Since under this condition the shutter will stay permanently open, drive car to the nearest FIAT Service Station for the necessary thermostat check up.

To drain cooling system: unscrew engine drain cock **D** and radiator drain cock **C** some turns.

To refill, close drain cocks, bring water in engine radiator to max level, run engine for some minutes at idling speed and then top up once more.

## Generator, water pump and fan drive belts tension



Through use the belts can slacken and slip. Hence have belts checked periodically for proper tension which is correct when under a pressure of about 22 lbs, sag is 1 to 1,5 cm ( $\frac{1}{3}$ " to  $\frac{1}{2}$ "). If necessary, adjust as follows:

### Generator drive belt:

- slacken the two support nuts **B**;
- rotate support **A** outwards until tension is correct. Retighten support nuts **B**.

### Water pump and fan drive belt:

- Back out the three pulley-to-hub mounting nuts **C**.

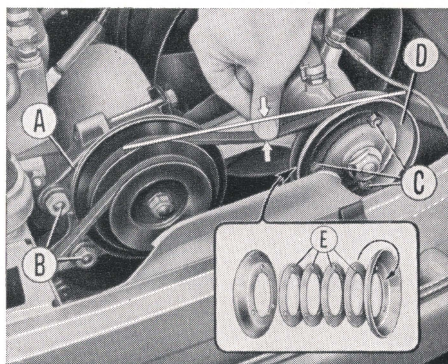

- Remove outer semi-pulley **D**, take out one (or more, depending on belt slackness) of the spacer rings **E** forming the pulley groove.
- One re-installing the pulley, the rings — if more than one was removed — should be suitably distributed on the two outer faces of the pulley.
- Secure the pulley by the three nuts **C**.

## IGNITION SYSTEM

### Ignition distributor

**Every 10.000 km (6,000 miles):** screw greaser cap **A** on distributor shank two or three turns. When cap is fully tightened in, repack with FIAT MR 3 grease. Wet wick **D** with some engine oil. Check also breaker point gap **C** which must be 0,47 to 0,53 mm (.019"-.021"); adjustment is obtained by suitably displacing the stationary contact carrier plate after slackening its screw **B**. Re-lock screw.

If contacts are dirty (oily) wipe with a gasoline-moistened cloth.

Following repeated adjustments, or sooner if required, replace contacts.

After setting breaker point gap adjust also engine idle speed rate.

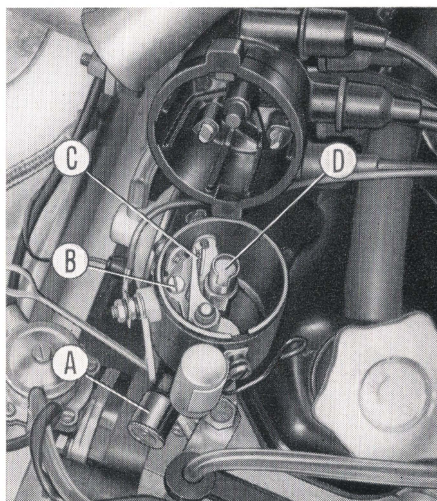

## Spark plugs

**Every 10.000 km (6,000 miles):** clean spark plugs removing all deposits also in the recess between central electrode porcelain liner and body (or better have them sanded) and check electrode gap (Marelli: 0,5-0,6 mm = .020"-.024"; A.C. Delco: 0,6-0,7 mm = .024"-.028").

## Ignition timing



This timing is necessary when the distributor shaft and/or camshaft have been removed.

If distributor is taken down without disturbing the crankshaft, no timing operation will be required after reassembly.

Time distributor to engine as follows:

— Make sure cylinder No. 1 is in the compression stroke, i.e., with both valves closed.

Bring crankshaft to the position in which the **mark** on generator and

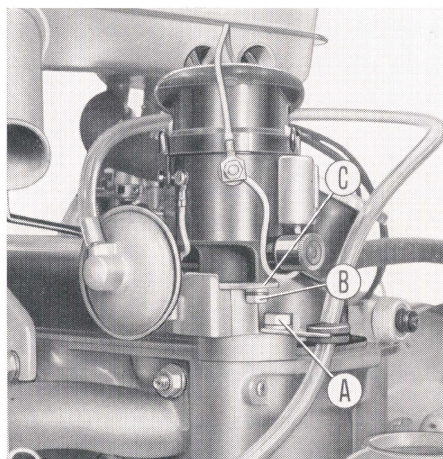
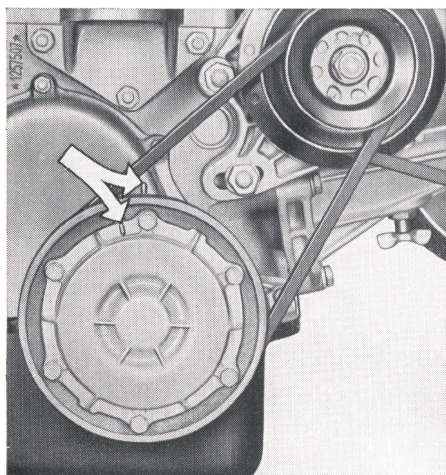

fan drive pulley will be located 13-14 mm (.51" to .55") ahead of the **mark** on timing gear cover; this corresponds to a 10° B.T.D.C. advance.

- Insert lower coupling (with support) on drive shaft toothed end and lock support to engine by screw **A**.
- Slacken screw **B** locking the distributor on vacuum advance corrector lever **C**.
- Remove distributor cap and rotate drive shaft by hand until rotor points to contact for firing in cylinder No. 1 (reference numbers for cable connection to cylinders in desired sequence are marked on cap). In this position, contacts are about to snap open (check first if max. contact distance is 0,47-0,53 mm = = .019"-.021").
- Lock distributor in this position by fully tightening screw **B**.
- Check cables for correct connection to spark plugs.

## POWER TRAIN

### *Clutch*



Should clutch show a tendency to slip, check that clutch pedal is set for an approximate 20 mm (.8") free travel. If necessary, re-adjust by the stretcher. Secure in position by locknut. To reach stretcher, remove bottom apron.

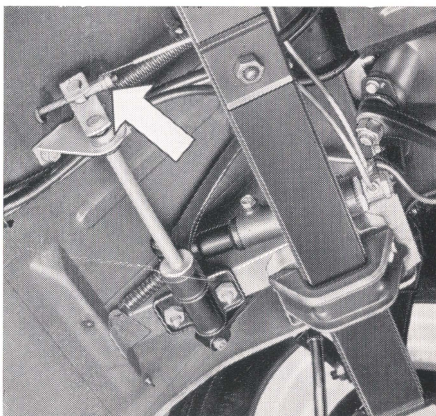

### *Transmission and differential*

**Every 10.000 km (6,000 miles):** check oil level which must reach plug bottom face.

**Every 30.000 km (18,000 miles):** renew oil. Let drip thoroughly before refilling.

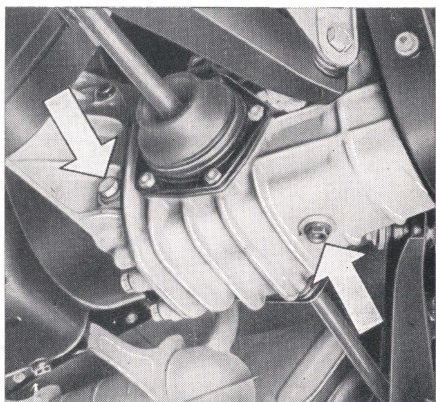

## BRAKES

### *Brake fluid reservoir*

**Every 10.000 km (6,000 miles):** check level and, if required, top up.

Checking this level more frequently, however, is a good practice.

Use exclusively the « **Special FIAT Blue Label fluid** » or equivalent non-mineral HD fluid.

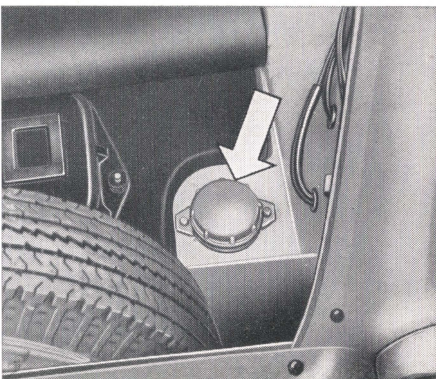

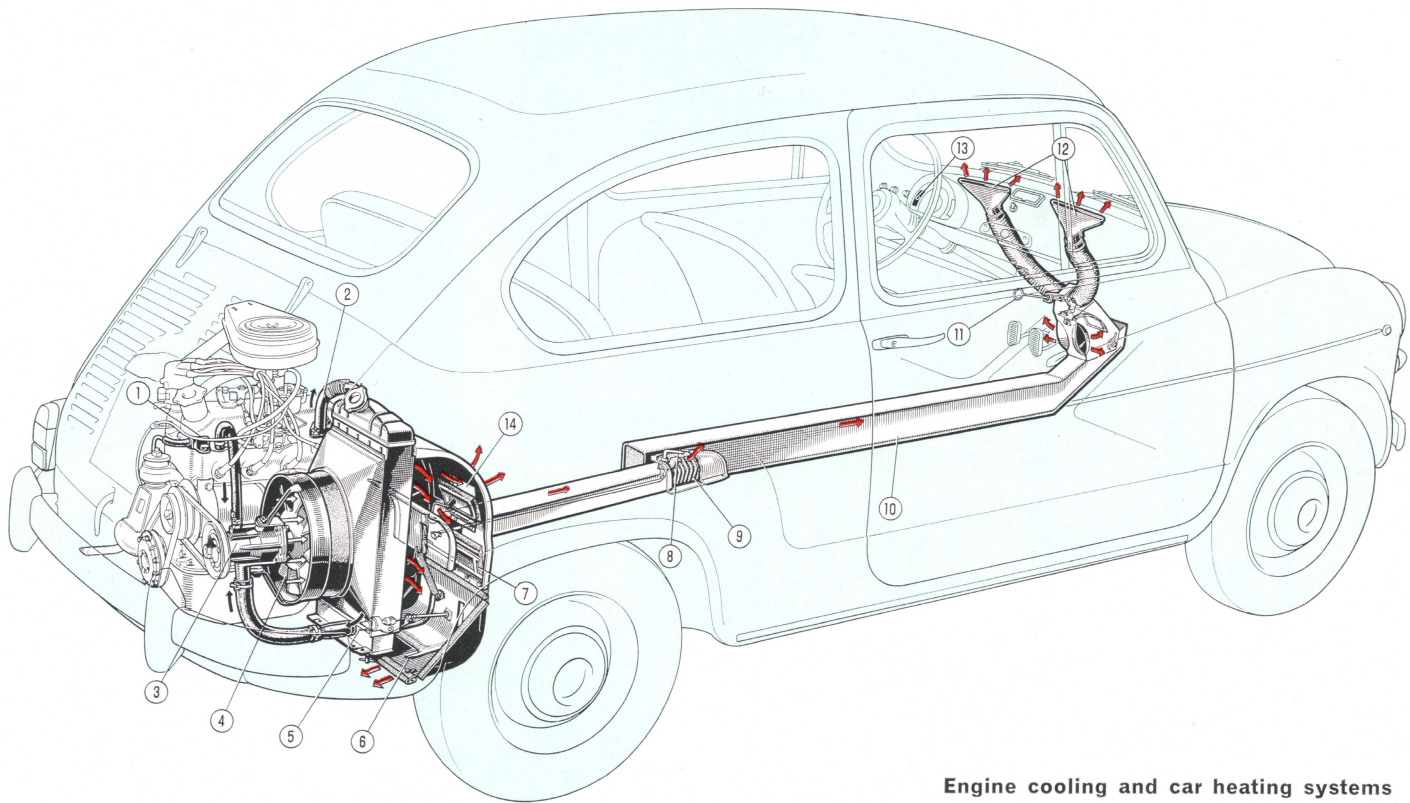

### Engine cooling and car heating systems

1. Thermostatic control for excessive water temperature indicator - 2. Water outlet pipe from cylinders - 3. Water pump - 4. Fan - 5. Thermostat, shutter control - 6. Shutter, air draft control in engine compartment - 7. Baffle in open position (warm air enters car) - 8. Baffle control lever - 9. Warm air

filter - 10. Longitudinal warm air conveyor - 11. Ring grab, warm air outlet shutters control - 12. Diffusers sending warm air against windshield - 13. Excessive water temperature indicator - 14. Shutter, for warm air admission through luggage space behind rear seat.

## Brake system



If pedal free travel has become excessive or if braking unbalance on one wheel is appreciable, have the entire system inspected at a FIAT Service Station; however, if an emergency arises wherein brakes must be adjusted before a Service Station can be reached, the following adjustment procedure is recommended.

### Brake shoe clearance:

- Make sure hand brake lever is in released position;
- depress brake pedal so as to force the shoes against drum;
- keeping the shoes in this position, turn nuts **A** until the cam contacts the shoe and then back the nuts abt. 20°.

This will set the shoe-to-drum heel clearance (which may be checked through the slots in drum, after removing the wheel) to 0,25 mm (.01");

- release the brake pedal and see that the wheel revolves freely.

Repeat the same operations on the other wheels.

Replace linings if worn to half their original thickness.

If linings are just greasy, wash in turpentine and scrub with a wire brush. Check seals for oil leaks.

**Air bleeding.** - In case brake system has been drained or some connection has been slackened, the system must be bled after refilling. This is a very delicate operation and should be entrusted to a FIAT Service Station. However, for those who decide to do the work themselves

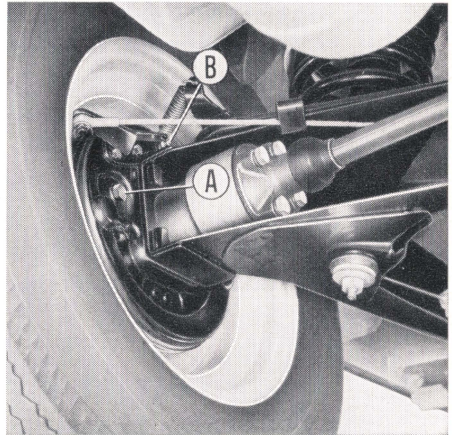

the following points have been outlined for their guidance:

- Wipe off any dirt from tip of bleeder connection **B** on top of each wheel cylinder. If necessary, unplug central hole. Fit one end of bleeder hose on wheel cylinder bleeder and slacken the connection half a turn.

- Immerse the hose other end in a transparent vessel partially filled with brake fluid.
- Pump pedal repeatedly and slowly, and watch the fluid running out of hose into vessel; stop pumping when fluid issues in a solid stream without bubbles.
- While keeping brake pedal depressed, tighten bleeder connection and remove bleeder hose. Clean connection tip of any fluid.
- Repeat bleeding operation on each wheel cylinder, making sure each time that fluid level in reservoir is sufficient. After bleeding the system, top up reservoir to fill mark.

**WARNING! Never re-use the fluid emptied into vessel unless it has been filtered very carefully.**

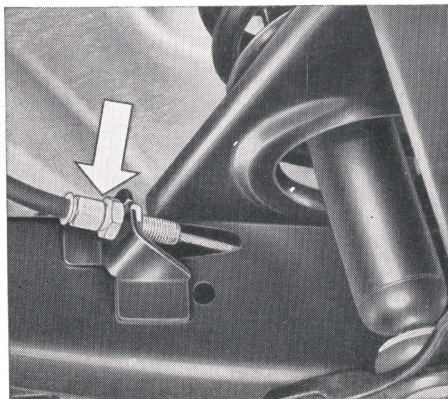

## ***Auxiliary brake***



To adjust hand lever stroke — after setting the shoe-to-drum clearance as described on page 31 — bring hand lever to rest position, pull lever up of two serrations, then rotate the two stretchers (one for each wheel). After adjusting the lever stroke, set the lever in rest position and check brake shoe clearance again.

## **S U S P E N S I O N S**

### ***Kingpins***

**Every 2.500 km (1,500 miles):** inject some FIAT Jota 1 grease in lubricator on top of each pin housing.

### ***Hydraulic shock absorbers***



Whenever dampening action becomes irregular have shock absorbers inspected at a FIAT Service Station.

## **S T E E R I N G   A N D   W H E E L S**

### ***Steering gear adjustments***



If excessive play in steering gear develops or if improper response to steering is noticed, have

steering mechanism inspected and adjusted at a FIAT Service Station. The adjustment must be carried out as follows.

a) **Backlash between worm screw and sector:**

- remove lower apron;
- remove the two adjustment plate fixing screws **A** and rotate eccentric bush by adjustment plate to bring sector closer to worm screw. Secure plate again by using the other fixing holes;
- should adjusting plate be already fixed in last hole (which would impede repositioning after rotation) remove plate from bush, rotate one or more serrations and secure. For this operation, the steering box must be removed from car.

b) **Play in worm screw roller bearings:**

- Screw up the adjuster ring **B**.

Both adjustments should eliminate any play without rendering steering too stiff.

### **Front wheel geometry**

Should an abnormal wear of tires be noticed, have the front wheel **toe-in and camber** checked.

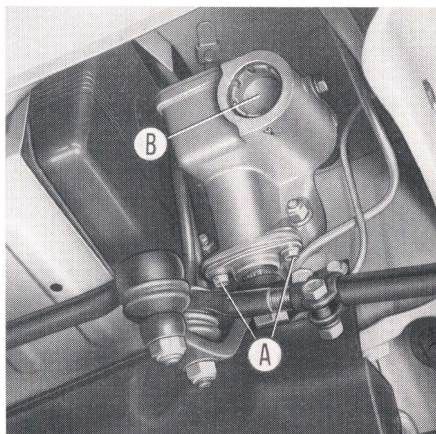

This check must be carried out with laden car. After loading, move the car a few yards so that suspension components will assume their natural setting under load. Toe-in measurements must be taken on the same points of wheels: measure in **A** (see illustration on next page), then move car until points **A** reach position **C** and take a new measurement - **A** must be = **C** + 0 to 2 mm (.08").

Camber measurements must be taken in the same way, except that **D** must be greater than **B** by 5-6 mm (.20"- .24").

Length of track rods is adjustable by turning in or out the sleeves after slackening the locking clamps.

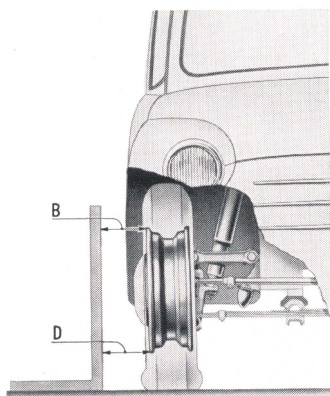
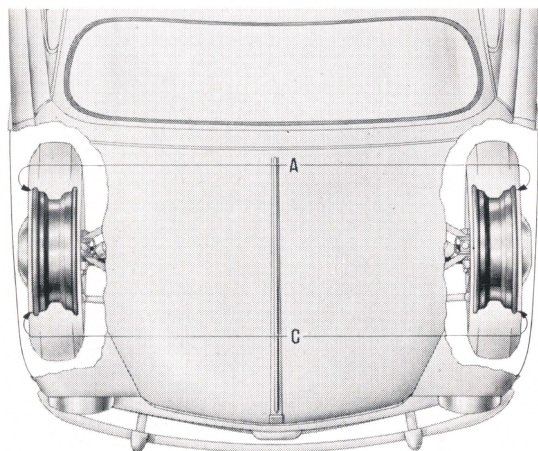

After adjusting track rod length as required, check that expansion slot in sleeve registers with clamp joint; with fully tightened clamp, joint faces must not be in contact.

**Every 30.000 km (18,000 miles):** have the same operations performed on **rear wheel** bearings.

### **Wheel bearings**



**Every 20.000 km (12,000 miles):**

have **front wheel** bearings lubricated with FIAT MR 3 grease and adjusted at a Service Station.

### **Tires**

**Every 500 km (300 miles):** check pressure with a gauge, not forgetting the spare wheel.

**NOTE** - See « *Safe Motoring Hints* » for instructions on how to equalize tire wear.

## **CAR HEATING**

### **Warm air filter**

If after long use the amount of warm air sent into car is found insufficient, clean air filter (9, page 16) located on longitu-

dinal air conveyor side. The filter must be cleaned with a soft brush or a low pressure air blast. If clogged, replace.

# GENERATING AND STARTING EQUIPMENT

## Battery

**Every 2.500 km (1,500 miles):** with battery at rest and cold, check electrolyte level and, if necessary, add **distilled water** up to the bottom of the well within each plug.

**In summer,** check level more often.

**Every 10.000 km (6,000 miles):** check terminals and clamps for tightness and cleanliness, coating them with pure ropy vaseline.

To reach battery, lift front compartment rubber mat **D** and unscrew the two hold-down knobs **A** of cover **B**.

To check electrolyte level just remove lid **C**.

If car must be garaged for a considerable time see « Safe Motoring Hints ».

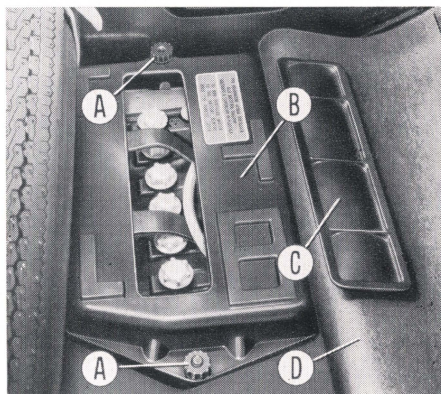

check wear and contact conditions of brushes and replace if necessary, seating the new brushes on commutator. When servicing starter, lubricate free wheel components with some FIAT Jota 2/M grease.

## Generator



**Every 30.000 km (18,000 miles):**

clean commutator carefully with a dry cloth; check brushes for wear and contact conditions, and replace if necessary, seating the new brushes on commutator.

Lubricate drive end ball bearing with FIAT MR 3 grease. Finally, pull out the lubricator wick, soak with thick oil and refit in place. Pack greaser cap with FIAT MR 3 grease before refitting.

## Starter



**Every 30.000 km (18,000 miles):**

clean commutator carefully;

## Generator regulator



**No tampering with this unit by unauthorized personnel should be permitted.** Owners should have the unit overhauled exclusively at a FIAT Service Station.

If a radio is fitted on the car, **do not insert any interference suppression condenser between terminal No. 67 and ground**, either of regulator or generator, since this would cause a rapid wear of the contacts of the unit which normally is not a source of radio interference.

Furthermore, **never interchange terminals No. 67 and No. 51** or else the regulator would be irreparably damaged.

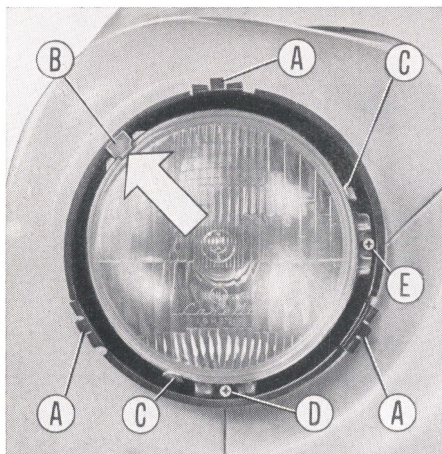

## LIGHTS

### Headlamp aiming



When headlamps have been totally disassembled (shell included) their beams must be re-aimed.

- A** = Distance between headlamp centers.
- B** = **C** minus 4 cm (1.57").
- C** = Height of headlamp centers above ground.

Place the unladen car (with tires inflated to the specified pressures) in the position shown in the illustration below.

**Horizontal aim checks with the high beams.**

The center of the light pool of each headlamp must lie on the vertical reference lines **a - a**.

**Vertical aim checks with the low beams.**

The separation line between the lit and unlit areas must be horizontal and lie on the horizontal reference line **b - b**. Turn screw **D** for beam vertical aiming (inclination) and screw **E** for beam horizontal aiming (divergence).

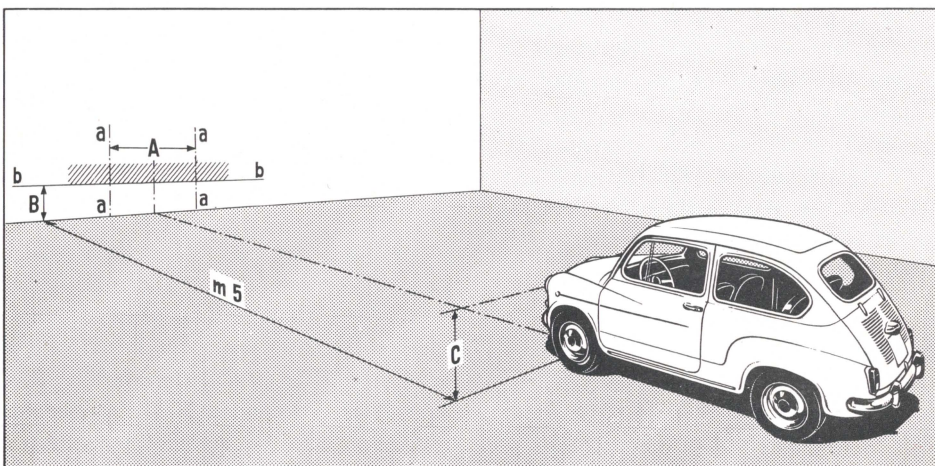

## Headlamps

Remove the frame pressure-mounted on the three spring fasteners **A**. Push outwards spring **B** and free the optical unit from the two retainer catches **C**. (See page 36). To replace bulb **F**, lift spring fastener **G** and pull out the bulb holder. The bulb is of the bayonet-coupled type.

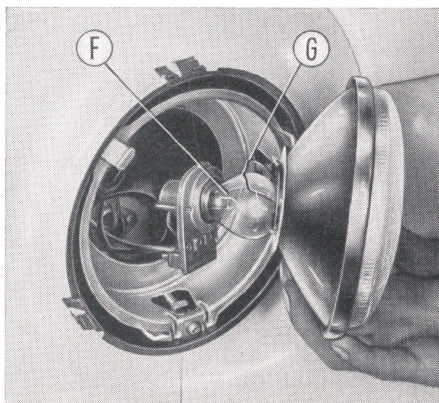

## Front parking and direction indicator lamps

- A.** Lens mounting screw.
- B.** Bayonet-coupled bulb.

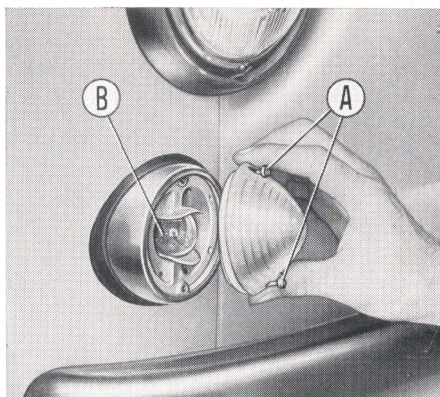

## Direction indicator side repeaters

To replace the bulb take off the rubber boot and bulb holder, operating from inside the fender.

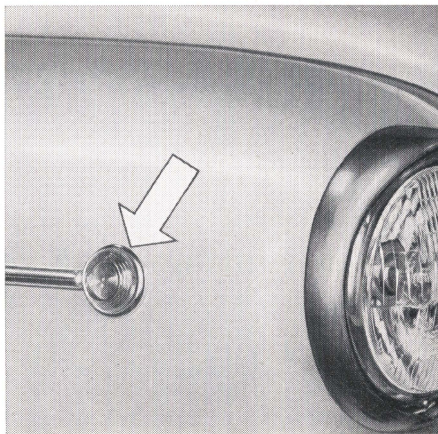

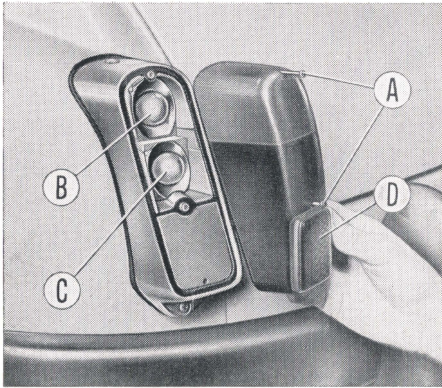

### ***Rear parking, stop and direction indicator lamps***

- A.** Lens mounting screws.
- B.** Bayonet-coupled bulb (direction indicator).
- C.** Bayonet-coupled bulb (parking and stop).
- D.** Reflex reflector.

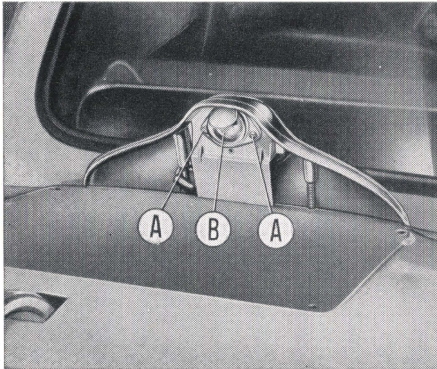

### ***Number plate lamp***

- A.** Lens and light cap mounting screws.
- B.** Lens.

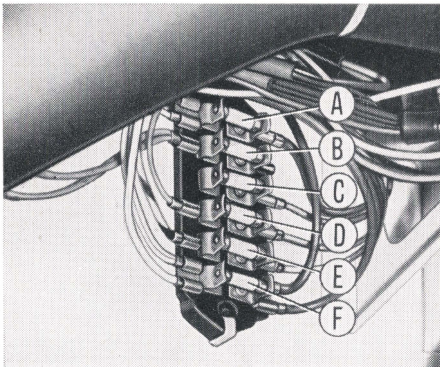

### ***Fuses***

Six, 8-Amp. fuses in a box under instrument panel. Before replacing a burnt fuse trace the cause of blowing, and remedy accordingly.

**Unprotected circuits:** battery charge with generator charge indicator, ignition, starting, insufficient oil pressure indicator, fuel level gauge and relevant reserve indicator, and excessive water temperature indicator.

## Wiring diagram

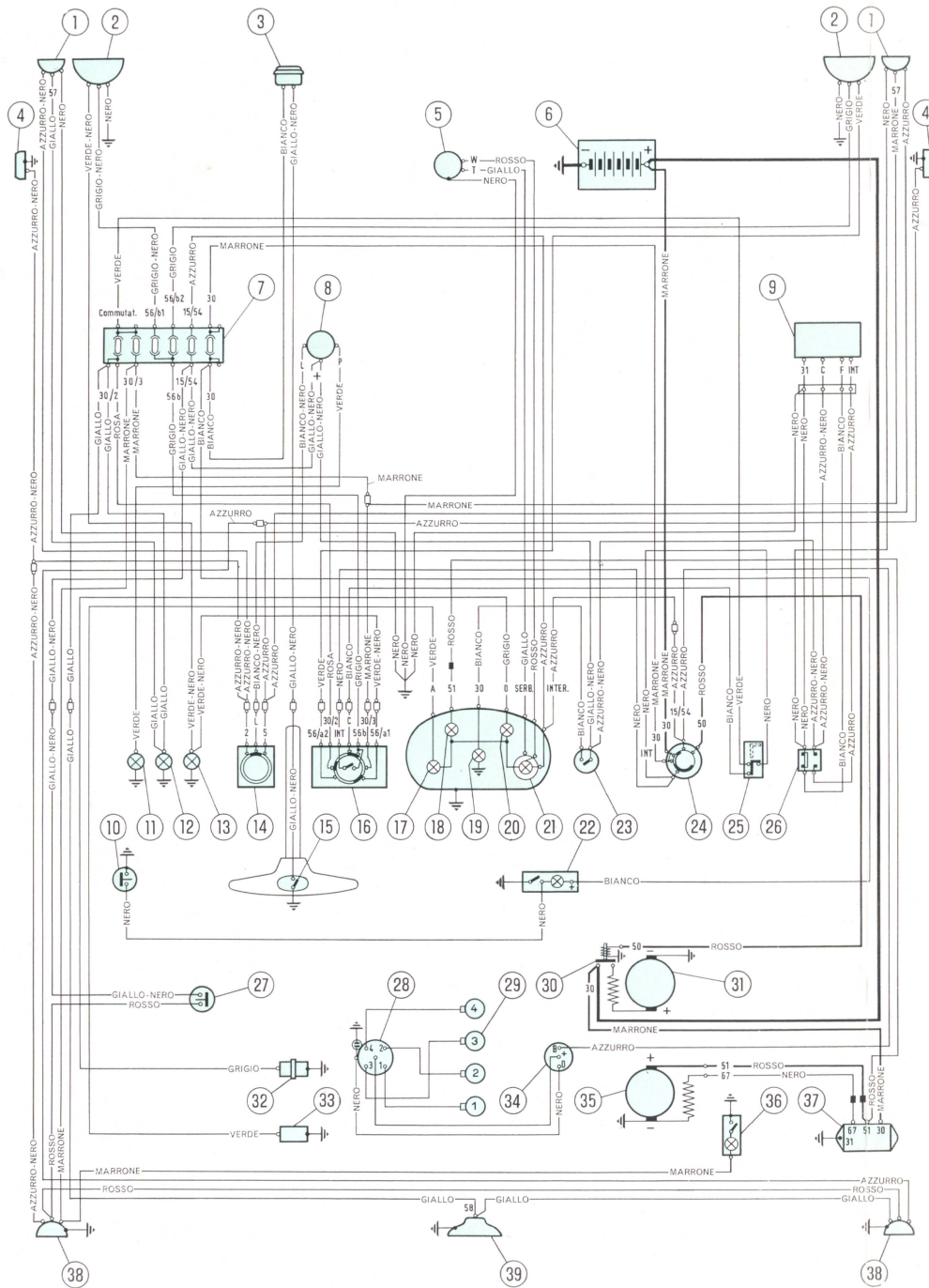

1. Front parking and direction indicator lamps.
2. Headlamps (high and low beams).
3. Horn.
4. Direction indicator side repeaters.
5. Fuel level gauge sending unit.
6. Battery.
7. 8-A fuses.
8. Winking device (flasher).
9. Windshield wiper motor.
10. Jam switch, between door and pillar, for courtesy light in rear view mirror.
11. Direction indicators pilot light.
12. Parking lights indicator.
13. High beam indicator.
14. Direction indicators switch.
15. Horn button.
16. Outer lighting change-over and headlamp flasher switch.
17. Excessive water temperature indicator.
18. Generator charge indicator.
19. Panel light bulb.
20. Insufficient engine oil pressure indicator.
21. Fuel level gauge, with reserve indicator.
22. Bulb incorporated in rear view mirror, for courtesy light, with toggle switch.
23. Instrument cluster light switch.
24. Ignition lock switch.
25. Outer lighting switch.
26. Windshield wiper switch.
27. Stop lights pressure-operated switch.
28. Ignition distributor.
29. Spark plugs.
30. Starter relay switch.
31. Starter.
32. Sending unit, for insufficient oil pressure indicator.
33. Thermostatic sending unit for excessive water temperature indicator.
34. Ignition coil.
35. Generator.
36. Engine compartment light, with automatic switch.
37. Generator regulator.
38. Rear parking, stop and direction indicator lamps.
39. Number plate lamp.

**Note.** - Mark **—** means that cable is provided with numbered strip or ferrule

### CABLE COLOR CODE

Azzurro = <b>Blue</b>	Grigio = <b>Grey</b>	Rosa = <b>Rosy</b>
Bianco = <b>White</b>	Marrone = <b>Brown</b>	Rosso = <b>Red</b>
Giallo = <b>Yellow</b>	Nero = <b>Black</b>	Verde = <b>Green</b>
Commutat. = <b>Switch</b>	Serb. = <b>Tank</b>	INT - Inter. = <b>Switch</b>

FUSE	PROTECTED CIRCUITS
<b>A</b> - Fuse No. 30	<ul style="list-style-type: none"> <li>— Horn</li> <li>— Lamp in rear view mirror</li> </ul>
* <b>B</b> - Fuse No. 15/54	<ul style="list-style-type: none"> <li>— Direction indicators and pilot light</li> <li>— Instrument cluster light</li> <li>— Stop lights</li> <li>— Windshield wiper</li> </ul>
* <b>C</b> - Fuse No. 56/b2	<ul style="list-style-type: none"> <li>— Right headlamp low beam</li> </ul>
* <b>D</b> - Fuse No. 56/b1	<ul style="list-style-type: none"> <li>— Left headlamp low beam</li> </ul>
* <b>E</b> - Fuse No. 30/3	<ul style="list-style-type: none"> <li>— Left headlamp high beam</li> <li>— High beam indicator</li> <li>— Front right parking lamp</li> <li>— Rear left parking light</li> <li>— Engine compartment light</li> </ul>
* <b>F</b> - Fuse No. 30/2	<ul style="list-style-type: none"> <li>— Right headlamp high beam</li> <li>— Front left parking lamp</li> <li>— Parking lamps indicator</li> <li>— Rear right parking light</li> <li>— Number plate lamp</li> </ul>

\* With ignition ON.

## BODYWORK

### *Body-mounted mechanical units*



**Every 20.000 km (12,000 miles):** have their anchoring to body checked for proper tightness.

### *Door hinges*

**Every 20.000 km (12,000 miles):** lubricate these hinges with a brush dipped in engine oil.

## ACCESSORIES

### *Windshield washer*

To clean the jets and gauze filter in bottle proceed as follows:

- remove the jet hexagonal retainer nut and clean jet squirt hole accurately;
- clean gauze filter on bottle outlet pipe suction end.

In case of jet misorientation adjust as follows:

- loosen the screw on jet head, reposition the hexagonal retainer nut so as to direct the water squirt to top of wiper sweep arc and retighten the screw.

For windshield washer refilling see « Fill-up Data ».

## MISCELLANEOUS

### *Road test*



**Every 10.000 km (6,000 miles):**  
drive the car to a FIAT Service  
Station for an overall check on road

of the efficiency of all mechanical  
units, electrical equipment and body-  
work.

## TOOL KIT

The kit is contained in a bag located in front compartment, next to spare wheel,  
and includes:

- Wrench, double end, 8 x 10 mm.
- Wrench, double end, 13 x 17 mm.
- Punch, straight.
- Screwdriver, double-tipped.
- Wrench, socket, for spark plugs.
- Speed handle.
- Jack.



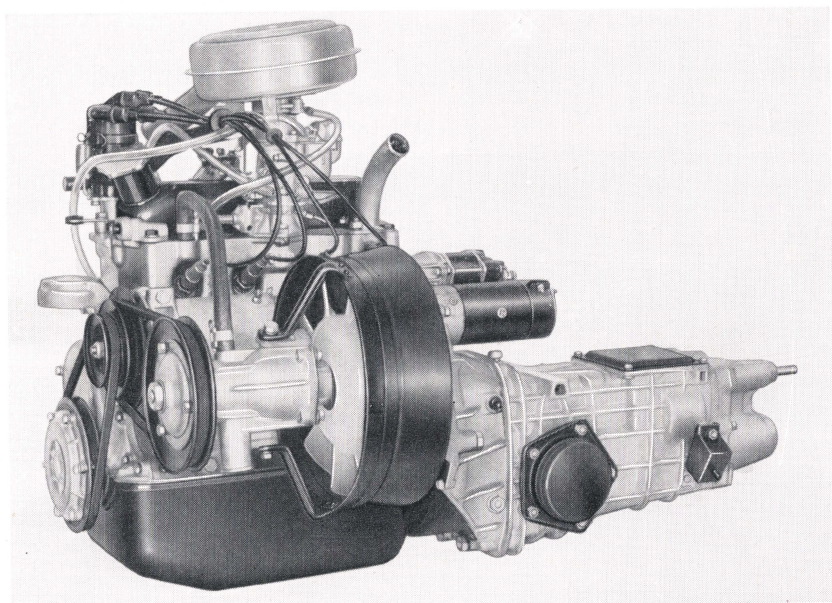
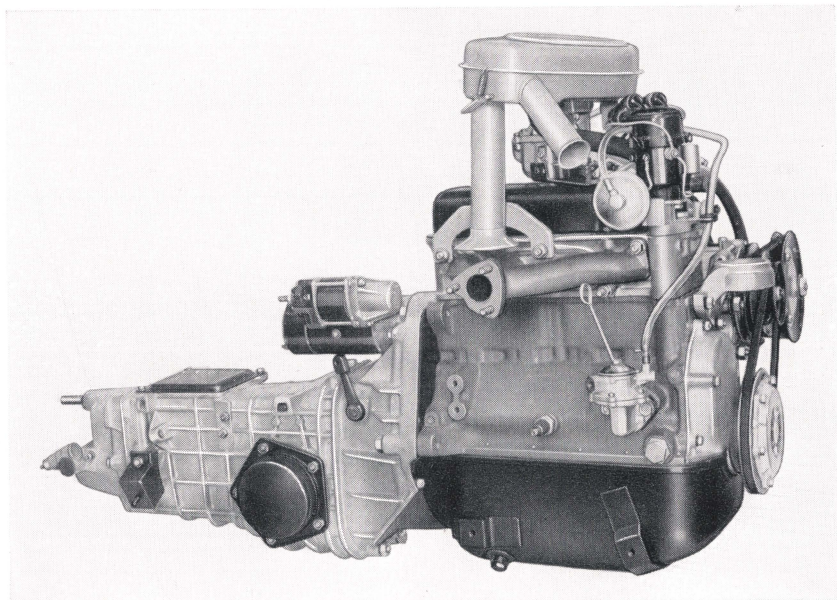

**Engine-transmission-differential unit**

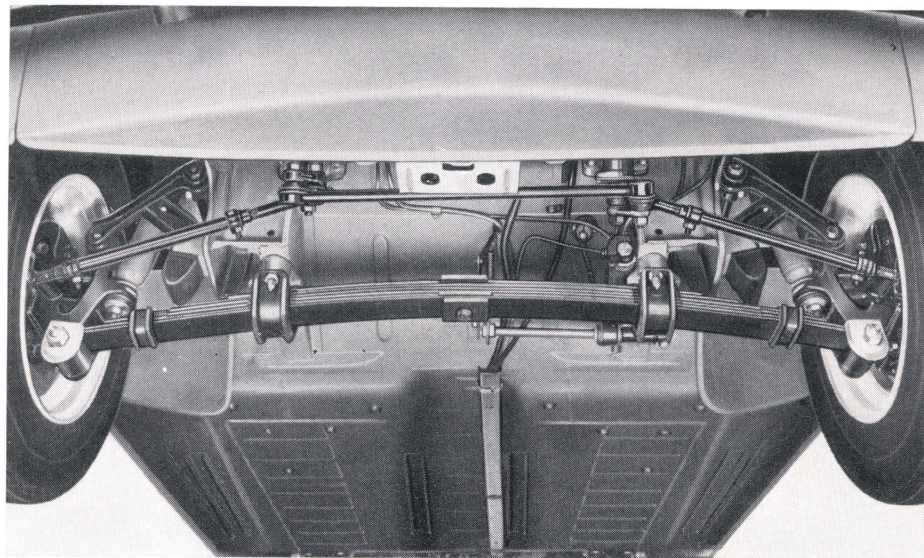

Front suspension

## POWER TRAIN

### CLUTCH

Single plate, dry.

Pedal free travel: abt. 20 mm (.8").

### TRANSMISSION AND DIFFERENTIAL

Four speeds forward (with 2nd, 3rd and 4th gears synchronized) and reverse.

Ratios:

1st gear . . .	3,385	3rd gear . . .	1,333
2nd » . . .	2,055	4th » . . .	0,896

Reverse . . . . . 4,275

Final drive ratio: . . . . . 8/39

Differential and final drive gears in transmission casing.

Drive to rear wheels by slip-joint, half-axle swing shafts.

## BRAKES

**Service:** hydraulically operated, self-centering, expanding-shoe type brakes, on all four wheels.

**Auxiliary:** mechanical, hand controlled, operating on rear wheel shoes.

Shoe-to-drum clearance, at heel . . . . . 0,25 mm (.01")

## SUSPENSION

### FRONT SUSPENSION

Independent wheels with hydraulic shock absorbers.

Semielliptic spring, transversally mounted, anchored to body in two points through the interposition of rubber pads and at the ends to the kingpin housings.

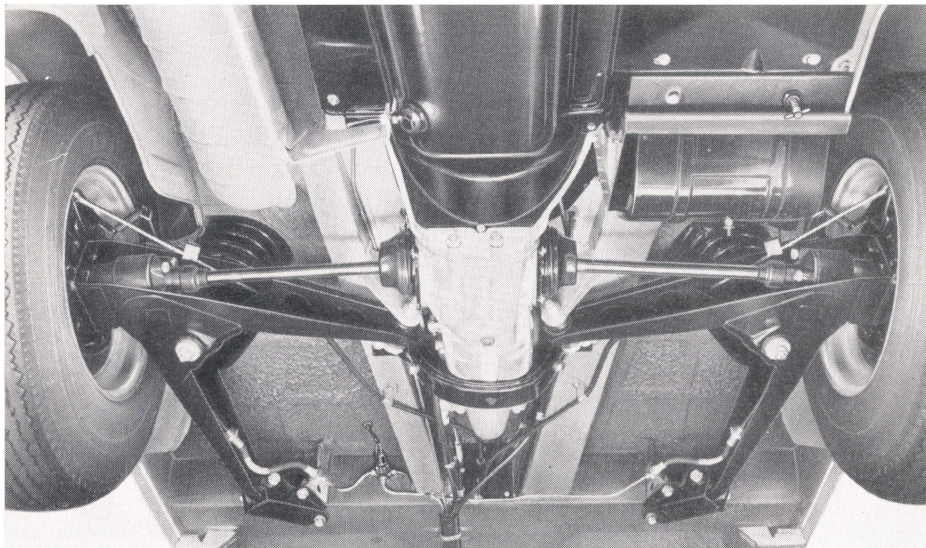

## Rear suspension

### REAR SUSPENSION

Independent wheels with coil springs and swinging arms. Hydraulic shock absorbers.

## STEERING AND WHEELS

### STEERING

Standard: left-hand drive. RHD is optional. Control by worm screw and

helical sector: ratio . . . . . 2/26

Independent and symmetric track rods.

Turning circle diameter . 8,70 m (28½ ft.)

Front wheel camber, measured at rim (fully laden) . 5-6 mm (.20"-.24")

Front wheel toe-in (fully laden) measured at rim . . 0-2 mm (0-.08")

### WHEELS AND TIRES

Disc wheels, with rims type . . 3 ½ x 12"

Low pressure, size 5,20-12 tires:

Michelin S.D.S. or Ceat D.B.,  
Pirelli Sempione or Rolle.

## ELECTRIC SYSTEM

Tension . . . . . 12 volts

### GENERATOR

FIAT	}	continuous output . . . . .	230 watts
		peak output . . . . .	320 watts
Cut-in speed (lights out)	}	engine, abt. . . . .	920 rpm
		car in top gear	20,5 km/h (12.7 m.p.h.)

### BATTERY

Capacity (at 20 hrs discharge rate) . . . . . 36 Ah

### STARTER

FIAT: power . . . . . 0,5 kW  
Direct engagement by electromagnet.

### FUSES

Six 8-Amps, in a fusebox under instrument panel, to the left of steering post.

## BULBS

LOCATION	TYPE	WATTAGE (12 Volts)
— Headlamps { high beam . . . . . { low beam . . . . .	} spherical, double filament .	} 45 40
— Front lamps { direction indicators { parking lights . . . . . — Tail lamps { stop lights . . . . . { parking lights . . . . .		
— Rear direction indicators . . . . .	spherical . . . . .	20
— Number plate lamp . . . . .	spherical . . . . .	5
— Engine compartment light . . . . . — Rear view mirror lamp . . . . .	} cylindrical . . . . .	5
— Instrument cluster light . . . . . — Direction indicator side repeaters — High beam indicator . . . . . — Parking lamps indicator . . . . . — Generator charge indicator . . . . . — Direction indicators pilot light . . . . . — Insufficient oil pressure indicator . . . . . — Fuel reserve indicator . . . . . — Excessive water temperature indicator . . . . .		

## BODY

Integral construction.

Two front-hinged doors, with front swivelling venti-panes and drop windows; safety lock on door opposite driver's seat. Driver's door locked by key.

Fixed-pane back and rear quarter windows.

Front compartment, housing the spare wheel, battery, fuel tank, brake fluid reservoir, windshield washer bottle and a space for luggage.

Engine compartment lid at rear.

Front adjustable, forward-tilting, bucket-type seats, with optional adjustable squabs.

Rear, fixed, bench-type seat with forward-folding back.

Luggage space behind rear seat whose back may be folded over cushion to increase luggage accommodation.

Utility shelf under instrument panel.

Two pouches on door inner trim panel.

Ashtray at center of facia.

Rear-view mirror with incorporated bulb for car interior illumination by reflection.

Two adjustable sun visors.

Front and rear bumpers with ornaments.

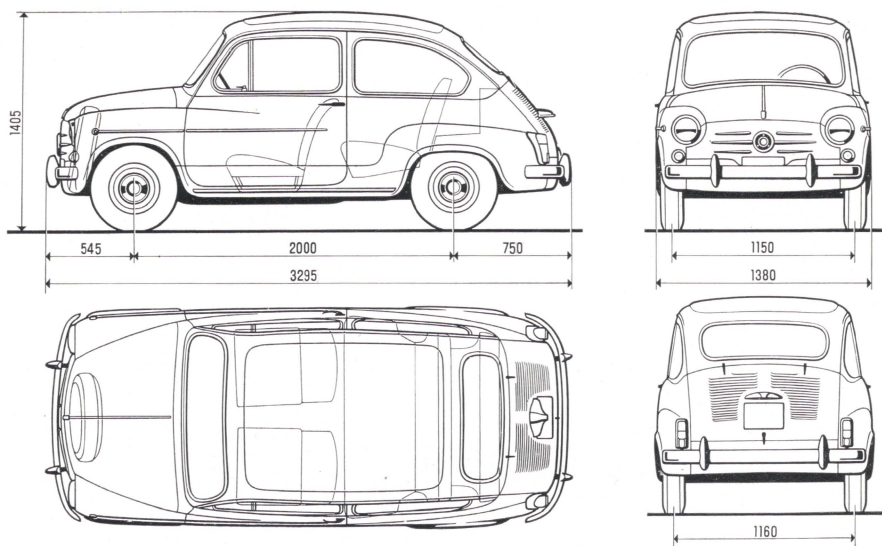

### Main dimensions

mm . . . .	545	750	1150	1160	1380	1405	2000	3295
in. . . . .	21.5	29.5	45.3	45.6	54.3	55.3	78.8	129.7

Height is intended with unladen car.

## PERFORMANCE

### Speeds

Maximum speeds after running-in (3000 km = 1800 miles):

	km/h	m.p.h.
— 1st gear . . . . .	30	19
— 2nd » . . . . .	45	28
— 3rd » . . . . .	70	44
— 4th » . . . . . abt.	110	68

### Gradients

Maximum climbable, fully laden:

— 1st gear . . . . .	30 %
— 2nd » . . . . .	17 %
— 3rd » . . . . .	10 %
— 4th » . . . . .	5,5 %

## WEIGHTS

Curb weight . . . . .	605 kg (1330 lbs)
Useful load . . . . .	4 persons plus 40 kg (88 lbs) of luggage
Gross weight (fully laden) . . . . .	925 kg (2.040 lbs)

# C O N V E R T I B L E

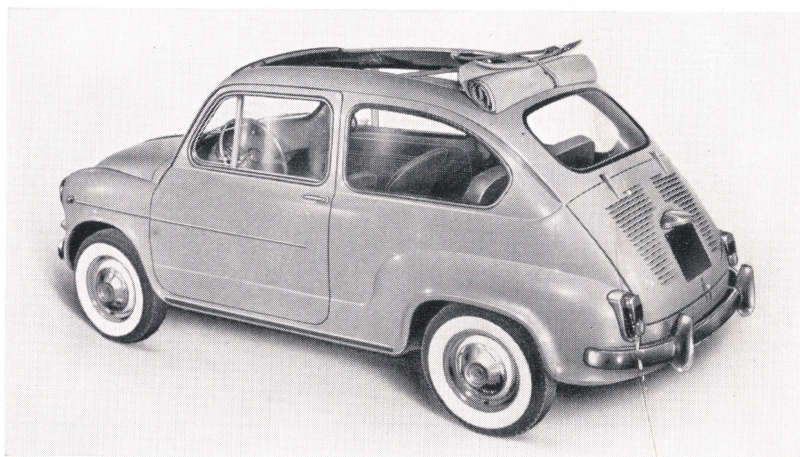

Only the special features and characteristics of the « Convertible » (folding top) which differ from those of the Standard « Hard Top » are briefly described here. For all remaining parts, refer to the information given on the foregoing pages.

## ROOF

To open the roof, roll back the imitation leather top as follows:

- a) release the two front latches;
- b) pull the top backwards, spread it completely and properly arrange the support bows;
- c) roll the top as shown;
- d) secure the roll by the strap inserted under the bracket provided on body.

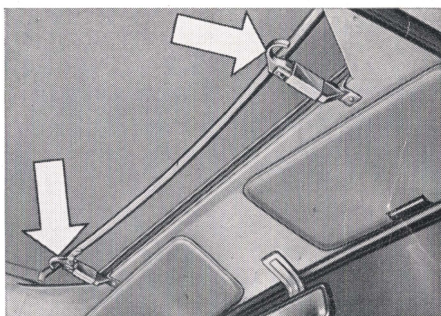

To clean the top wash with slightly soapy water and a sponge, or even simply with plain water.

## DIMENSIONS

Maximum height (unladen) . . . . . 1.415 mm (55.7")

## LUBRICANT CHARACTERISTICS

LUBRICANT	DATA	
<p><b>Fiat Oils</b> for engines (Suppl. 1 level, which satisfy MS sequences)</p>	<p>Oils for severe operating conditions are used in their different SAE viscosity grades. SAE designations are given also for « Multigrado » oils.</p>	<p>See the « Fill-up data table ».</p>
<p><b>Fiat Oils</b> for transmissions and axles (MIL-L- 2105 B)</p>	<p>SAE designation is given for the viscosity grade.</p>	<p>See the « Fill-up data table ».</p>
<p><b>Fiat-Jota 1 Grease</b> (Lithium-base chassis lubricant)</p>	<p>Drop point (Ubbelohde) . . . . . Worked penetration (60 strokes) . . . . .</p>	<p>min 180° C 310 to 340 <math>\frac{\text{mm}}{10}</math></p>
<p><b>Fiat-Jota 2/M Grease</b> (Lithium-base, N.L.G.I. No. 3, filled with MoS<sub>2</sub>)</p>	<p>Drop point (Ubbelohde) . . . . . Worked penetration (60 strokes) . . . . .</p>	<p>min 180° C 265 to 295 <math>\frac{\text{mm}}{10}</math></p>
<p><b>Fiat MR 3 Grease</b> (Lithium-base, N.L.G.I. No. 3)</p>	<p>Drop point (Ubbelohde) . . . . . Worked penetration (60 strokes) . . . . . Worked penetration after 24 hrs at -20° C (-4° F) . . . . .</p>	<p>min 180° C 235 to 255 <math>\frac{\text{mm}}{10}</math>  min 160</p>
<p><b>Special Fiat Blue Label fluid</b> (SAE 70 R 3)</p>	<p>Heavy Duty non-mineral grade . . . . .</p>	<p style="text-align: center;">—</p>

## FILL-UP DATA

ITEM	QUANTITY				REFILL
	lt	kg	U.S. Units	B.G. Units	
Fuel tank . . . . .	27	—	7.13 Gals.	5.94 Gals.	Regular gasoline
Radiator and water jackets . . . . .	4,5	—	4.80 Qts.	4.00 Qts.	Water <sup>(1)</sup>
Sump and filter <sup>(2)</sup> . . . . .	3,25	2,9	3.5 »	2.8 »	FIAT oil <sup>(4)</sup>
Transmission and differential	1,5	1,4	1.5 »	1.3 »	FIAT W 90/M oil (SAE 90 EP)
Steering box . . . . .	0,12	0,11	.13 »	.11 »	
Brake system . . . . .	0,28	0,28	.30 »	.25 »	Special FIAT Blue Label fluid or equi- valent HD non-mi- neral grade
Shock absorbers { front . . . . .	0,15	0,135	.16 »	.13 »	FIAT S.A.I. oil
{ rear . . . . .	0,12	0,11	.13 »	.11 »	
Windshield washer . . . . .	—	<sup>(3)</sup>	—	—	Water and FIAT D.P./1 liquid (concentrated solution) or TRICO XAW 30 cleaner.

<sup>(1)</sup> When temperature is close to 0° C change to good commercial grade anti-freeze mixtures (See « Safe Motoring Hints »).

<sup>(2)</sup> Total capacity of sump, filter and lines is 3,25 kg (3.70 U.S. Qts. - 3.10 G.B. Qts.). The amount tabulated is the requirement for periodical oil changes.

<sup>(3)</sup> 0,75 kg pure water plus 0,017 kg (2,28% in weight) (Summer) or 0,034 kg (4,56% in weight) (Winter).

<sup>(4)</sup> See following table for grades:

TEMPERATURE	FIAT Single-grade Oil	FIAT « Multigrado » Oil
	Supplement 1 level oils which satisfy MS sequence requirements	
Below -15° C (10° F) (minimum)	VS 10 W (SAE 10 W)	—
From 0° to -15° C (32° F to 10° F) (min.)	VS 20 W (SAE 20 W)	10 W - 30
Above 0° C (32° F) (minimum)	VS 30 (SAE 30)	20 W - 40
Above 30° C (90° F) (average)	VS 40 (SAE 40)	

**WARNING:** Never top up with oils of other grades or Makes - When starting to use these detergent oils on engines other than new the lubrication system must first be **thoroughly flushed** (See « Safe Motoring Hints »).

### TIRE PRESSURES

Front tires . . . . . 1,00 kg/cm<sup>2</sup> (14.2 p.s.i.) | Rear tires . . . . . 1,60 kg/cm<sup>2</sup> (22.8 p.s.i.)

The descriptions and illustrations appearing in this book are not binding. FIAT, therefore, reserves the right — while retaining the basic features of the Models herein described and illustrated — to make at any time, and without necessarily bringing this book up to-date, any alteration to units, parts or accessories deemed expedient for improvement or for any manufacturing or commercial reason.

---

**FIAT — DIPARTIMENTO NORME E PUBBLICAZIONI — Corso G. Agnelli, 200 — TORINO - Italy**  
**PRINTED IN ITALY** - 20th ed. (35<sup>a</sup>) - PRINT No. 603.00.240 - VIII-1964 - 5000 - S.A.N. Torino